



Authentic Repaint

# CITYCRAFT

## PAPERMODELS

# LOT POLISH AIRLINES



## BOEING 737 MAX 8

### LOT (Polish Airlines) Boeing 737 MAX 8 079

LOT Polish Airlines, legally incorporated as Polskie Linie Lotnicze LOT S.A. (Polish pronunciation: [lot], flight), is the flag carrier of Poland. Established in 1928, LOT was a founding member of IATA and remains one of the world's oldest airlines in operation. With a fleet of 75 aircraft as of 2021, LOT Polish Airlines is the 18th largest operator in Europe with over 120 destinations across Europe, Asia and North America.

The airline was founded on 29 December 1928 by the Polish government during the Second Polish Republic as a self-governing limited liability corporation, taking over existing domestic airlines Aerolot (founded in 1922) and Aero (founded in 1925), and began operations on 1 January 1929. The first aircraft used by LOT were Junkers F.13 and Fokker F.VII with the inaugural international service to Vienna, Austria, beginning on 2 August 1929

The Boeing 737 MAX is the fourth generation of the Boeing 737, a narrow-body airliner manufactured by Boeing Commercial Airplanes (BCA), a division of American company Boeing. It succeeds the Boeing 737 Next Generation (NG) and competes with the Airbus A320neo family. The 737 MAX is based on earlier 737 designs, with more efficient CFM International LEAP-1B engines, aerodynamic changes, including its distinctive split-tip winglets, and airframe modifications. The new series was announced on August 30, 2011. It took its maiden flight on January 29, 2016 and was certified by the U.S. Federal Aviation Administration (FAA) in March 2017. The first delivery was a MAX 8 in May 2017 to Malindo Air, with whom it commenced service on May 22, 2017.

Scale: 1:100  
Length: (395mm)  
Width: (358mm)  
Parts: 300 (12 pages)

Attach the parts in order.  
A1 - I6  
You can choose to make either a ground style (With Wheels)  
or an in-flight style (without wheels) aircraft.



# LOT POLISH AIRLINES

\*This model is designed for papercraft and is different in several ways from the real plane

\*Build the model by carefully reading the Assembly Instructions.

\*The final size of the model may vary slightly depending on the configuration of your printer



Authentic Repaint

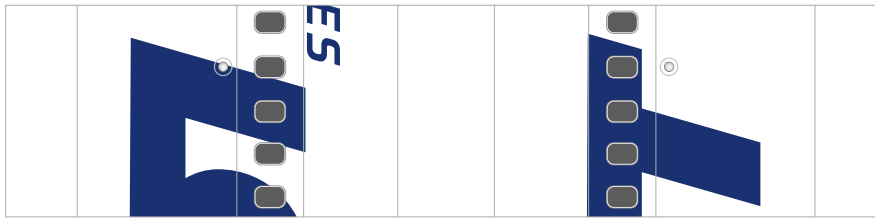

A15

A37

A37

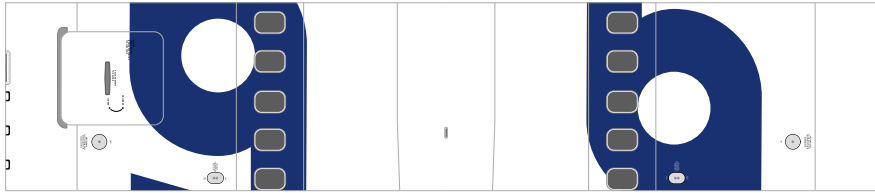

A14

A22

A23

A24

A25

A26L

A27L

A28

A30U

A26R

A27R

A29

A30D

A31L

A32

A33

A34

A31R

A47

A48

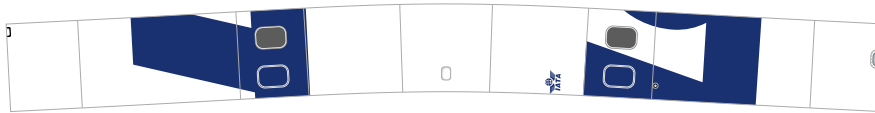

A13

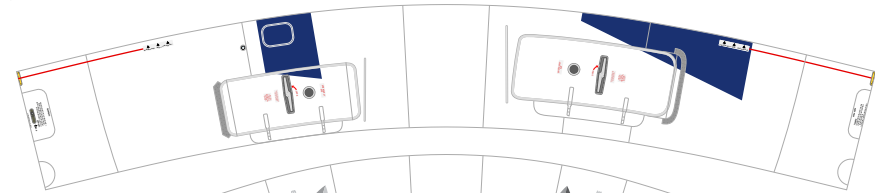

A12



A11

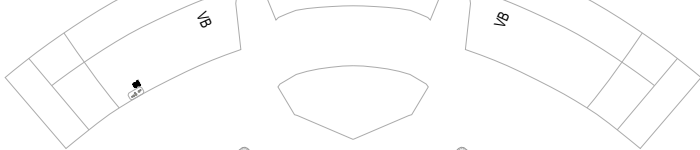

A10

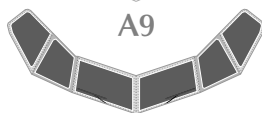

A9

A8

A38

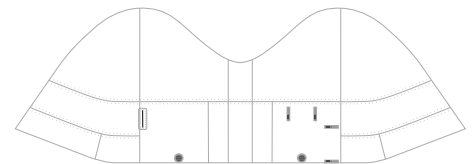

A21

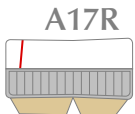

A17R

A39

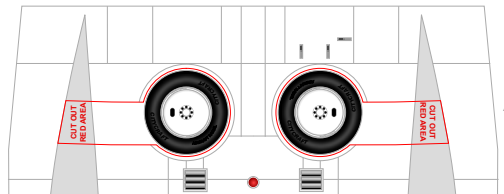

A20

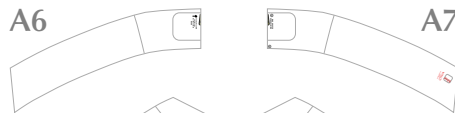

A6

A7

A40

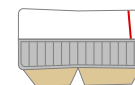

A17L

A41

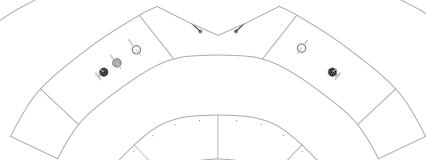

A5

A42

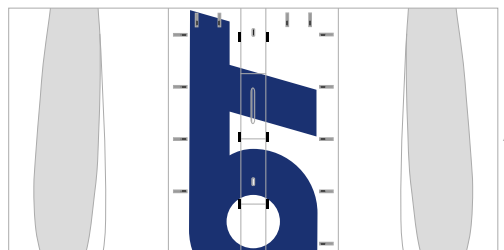

A19



A4

A43



A3

A44



A2

A45

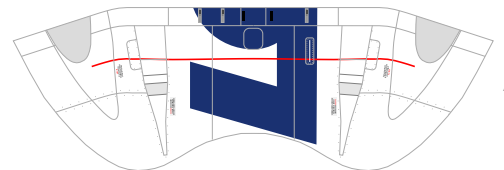

A18

A1

A46

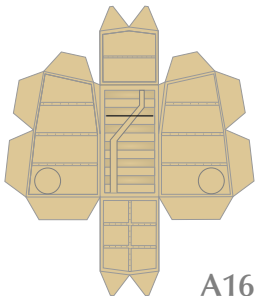

A16



Authentic Repaint

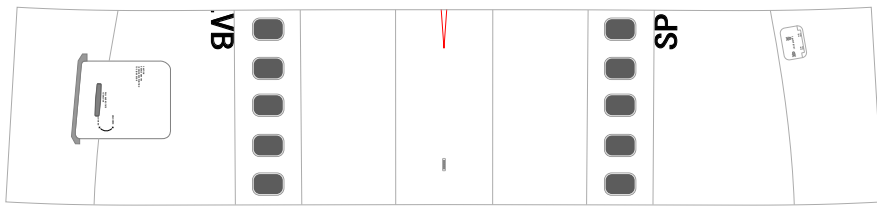

B6

B7L



B8L



B8L



B8L



B7R



B8R



B8R



B8R



B9

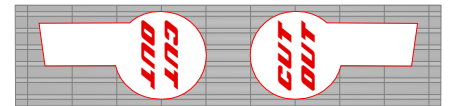

B5

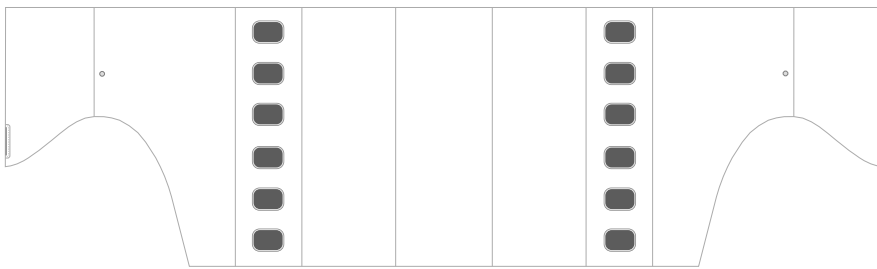

B4

B10

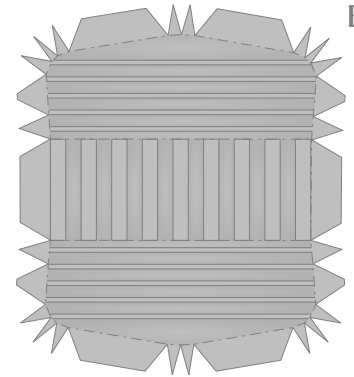

B11L



B12L



B11R



B12R

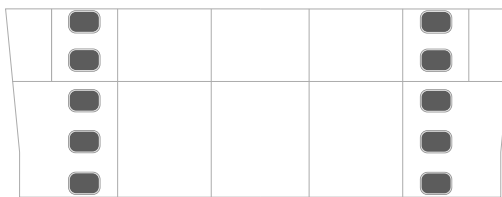

B3

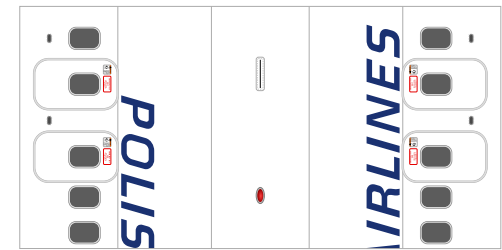

B2

B13L



B14L

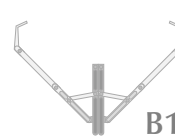

B15L



B16L



B17L\*



B18L\*



B19L\*



B20L\*



B21L\*



B13R



B14R

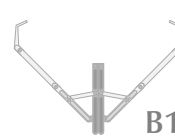

B15R



B16R



B17R\*



B18R\*



B19R\*



B20R\*



B21R\*



B1

B22L

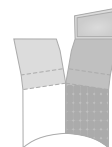

B22R

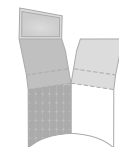

B23L



B23R





Authentic Repaint

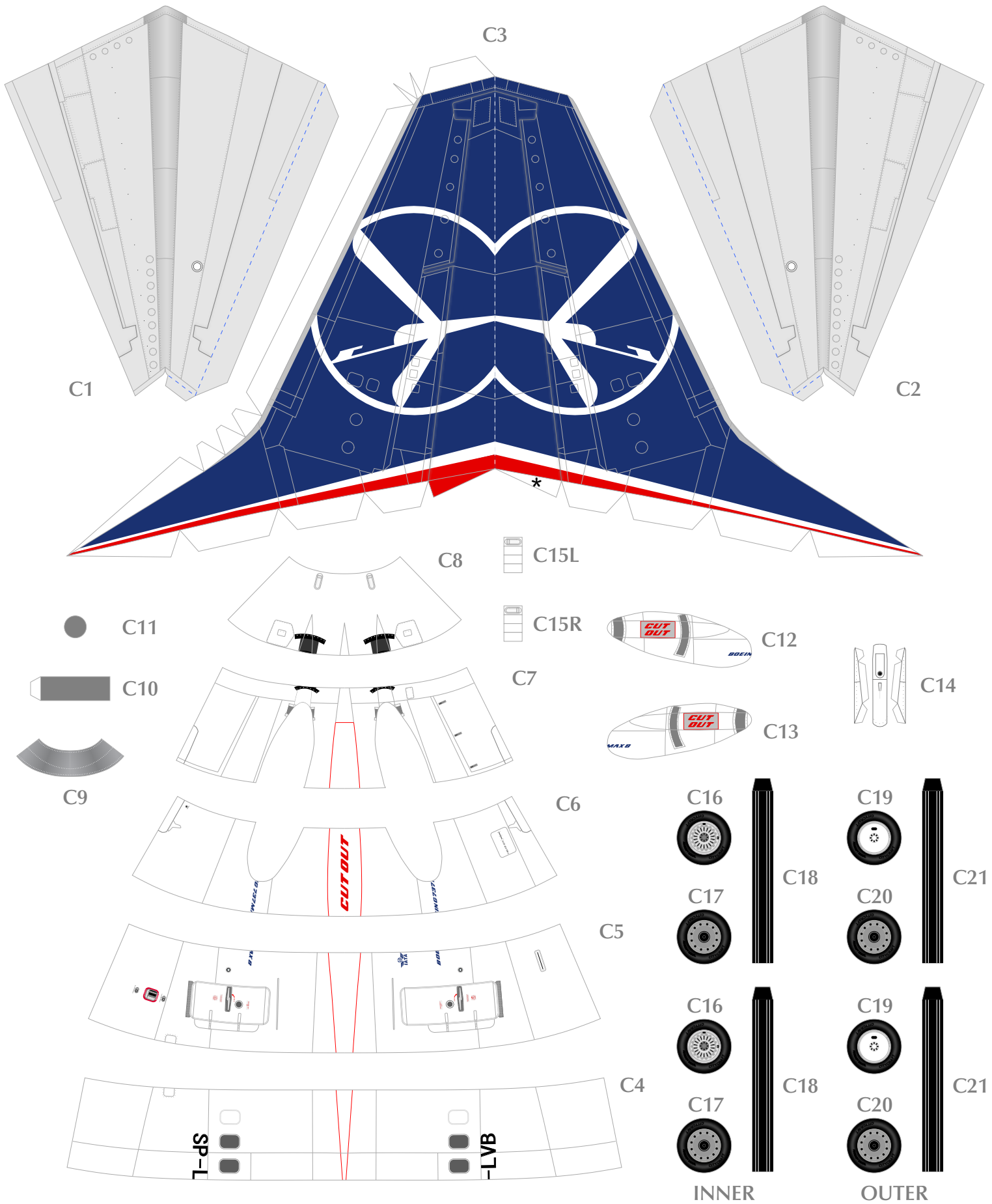



Authentic Repaint

Engines: CFMI Leap 1B

By Mario Solorzano

D1L



D2L

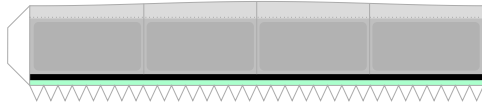

D1R



D2R

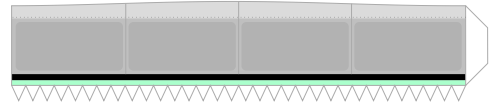

D3L



D24L



D24R



D3R



D4L

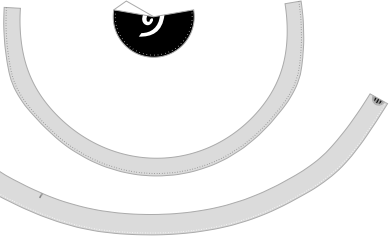

D4R

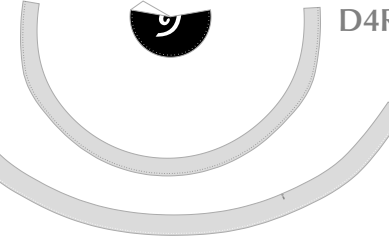

D5L



D25L



D5R

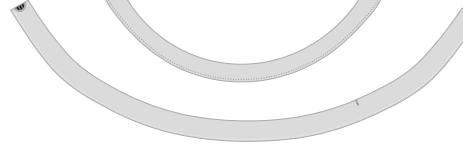

D6L

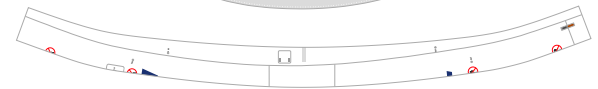

D25R



D6R

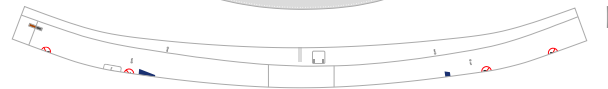

D7L

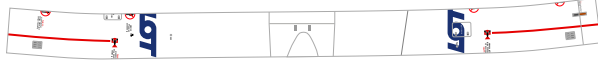

D26L



D7R

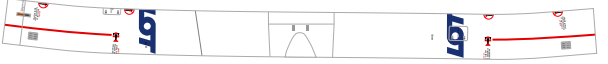

D8L

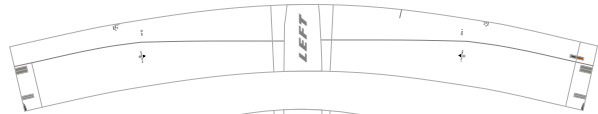

D26R



D8R

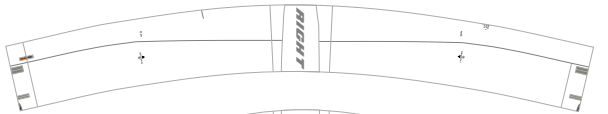

D9L

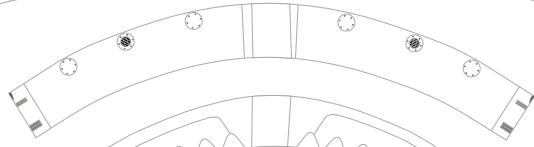

D27L



D9R

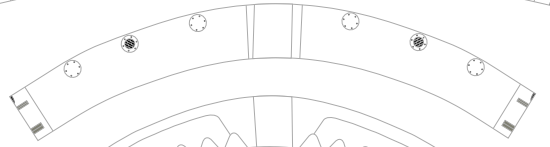

D10L

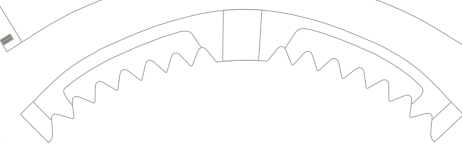

D27R



D10R

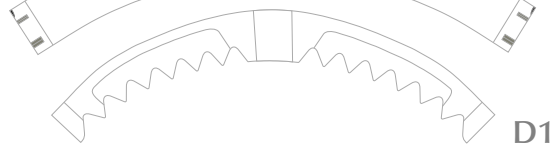

D11L



D18L

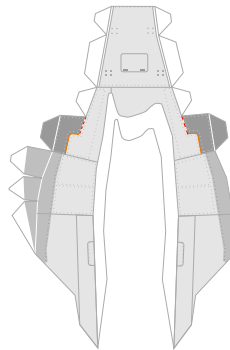

D11R



D18R

D12L

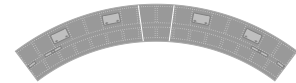

D12L

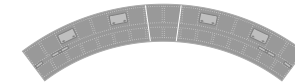

D13L



D13L



D14L



D14L

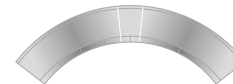

D15L



D15L



D16L



D16L



D17L



D17L



D21L



D22L

D23L

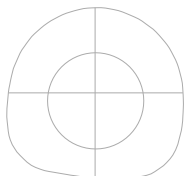

D19L

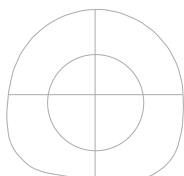

D20L

D24L

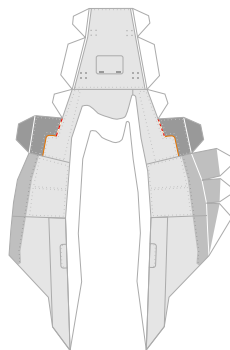

D24R



D21R



D22R

D23R

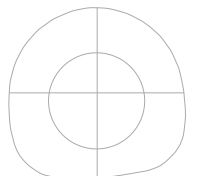

D19R

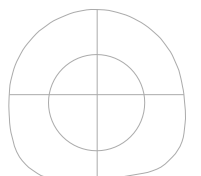

D20R



Authentic Repaint

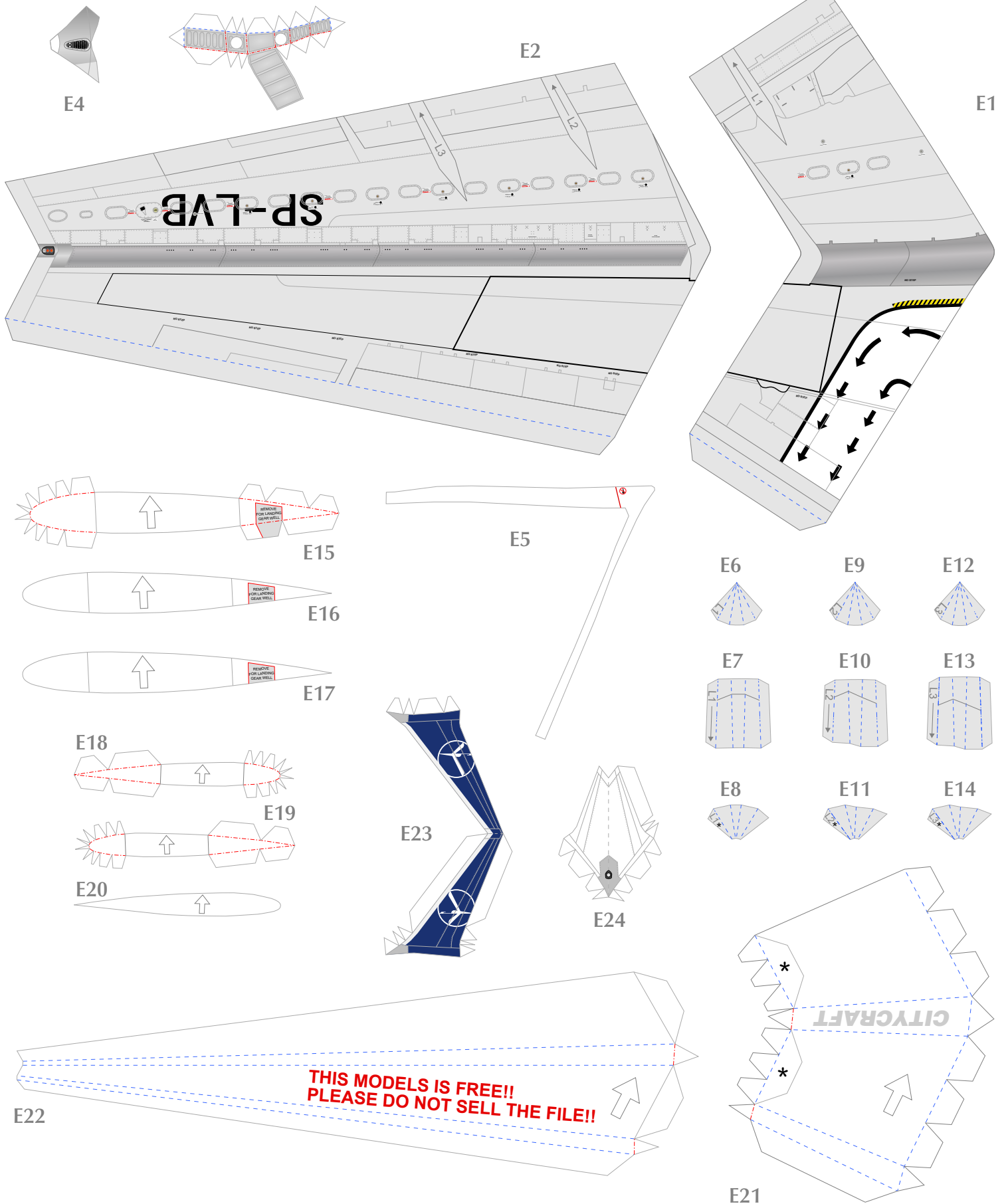

**THIS MODELS IS FREE!!  
PLEASE DO NOT SELL THE FILE!!**





Authentic Repaint

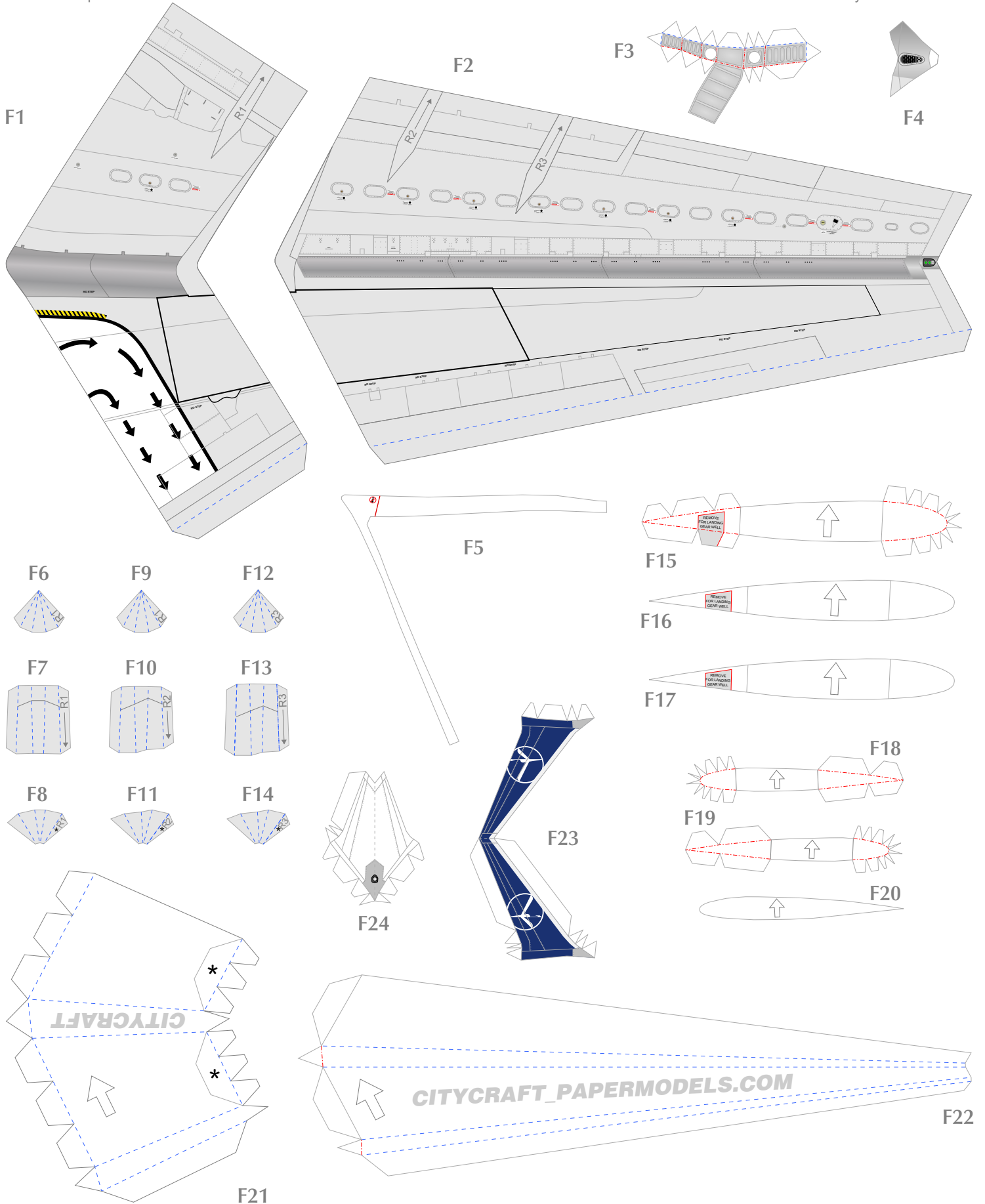

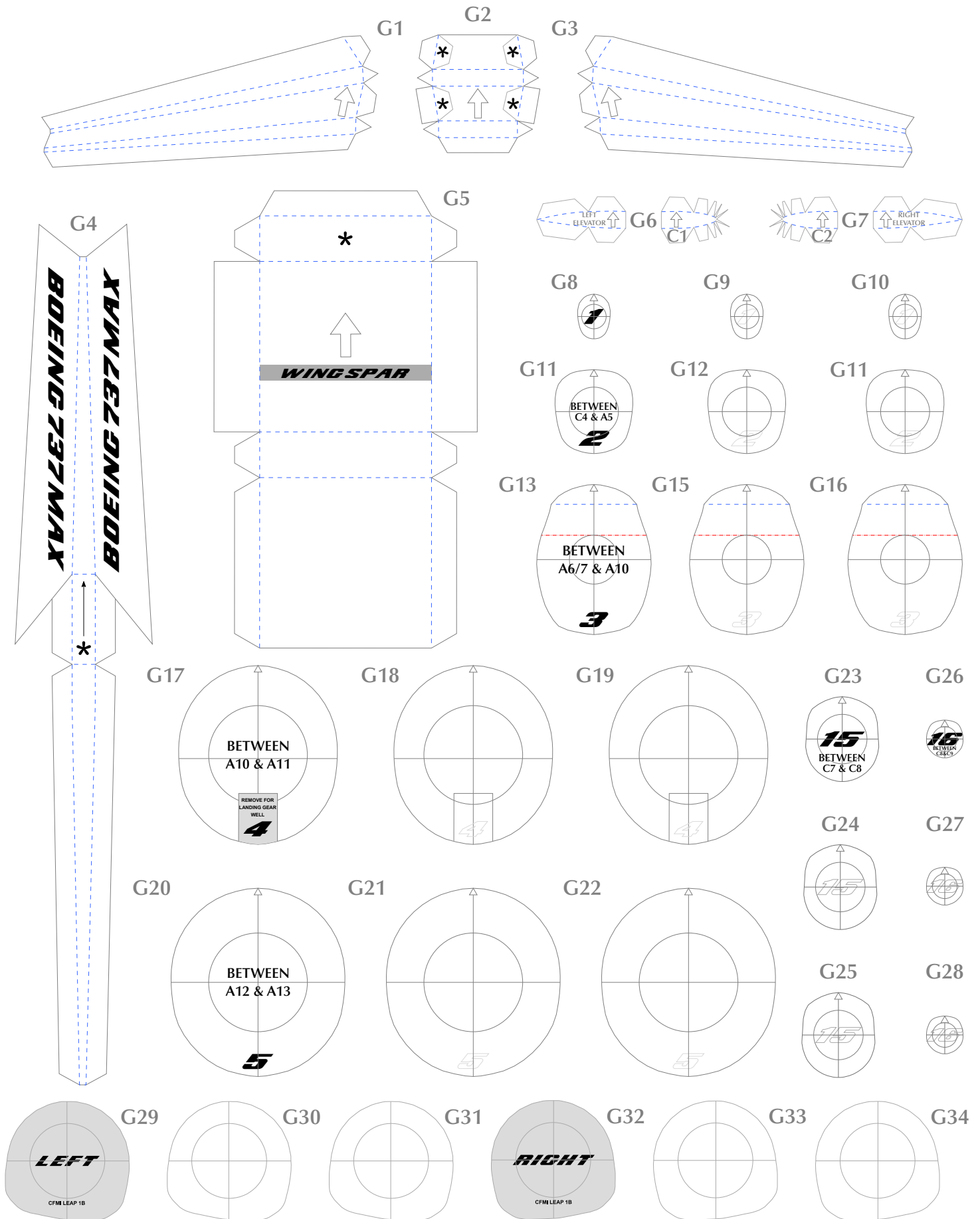





Authentic Repaint

By Mario Solorzano

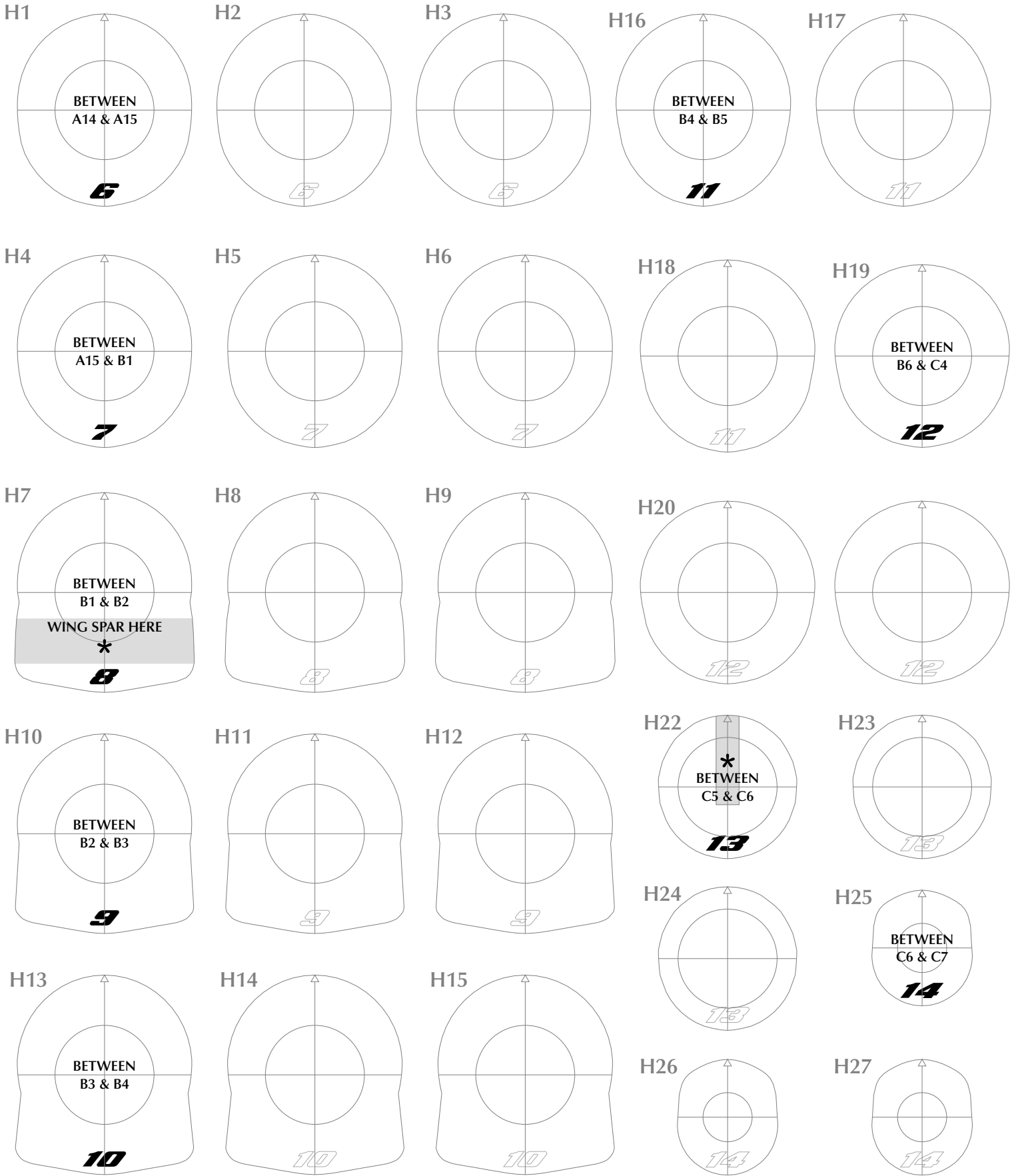



Authentic Repaint

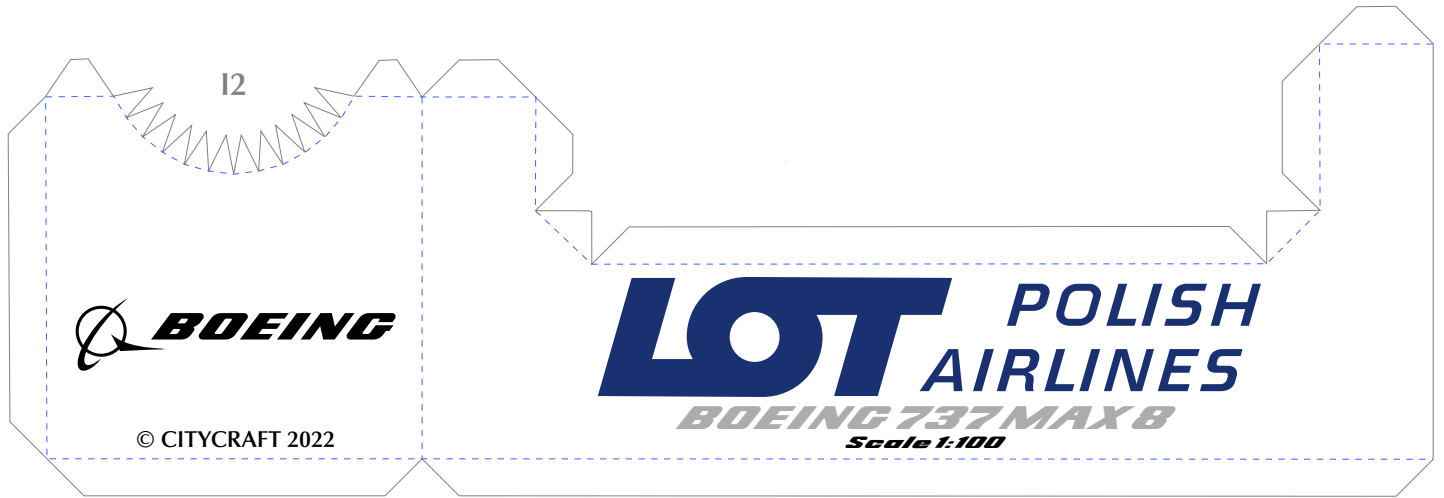
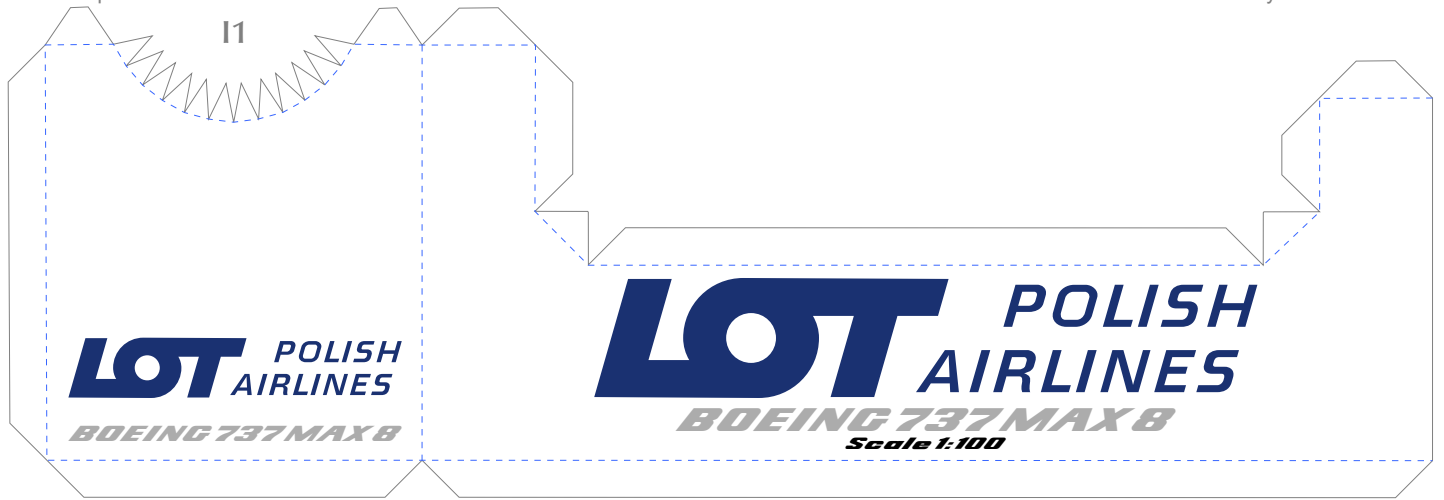

I3

I5

I4



CITYCRAFT  
PAPERMODELS



© 2022 CityCraft All Rights Reserved  
Model designed by (Mario Solorzano)  
<https://citycraftpapermodels.wixsite.com/citycraft>

**THIS MODELS IS FREE!!  
PLEASE DO NOT SELL THE FILE!!**

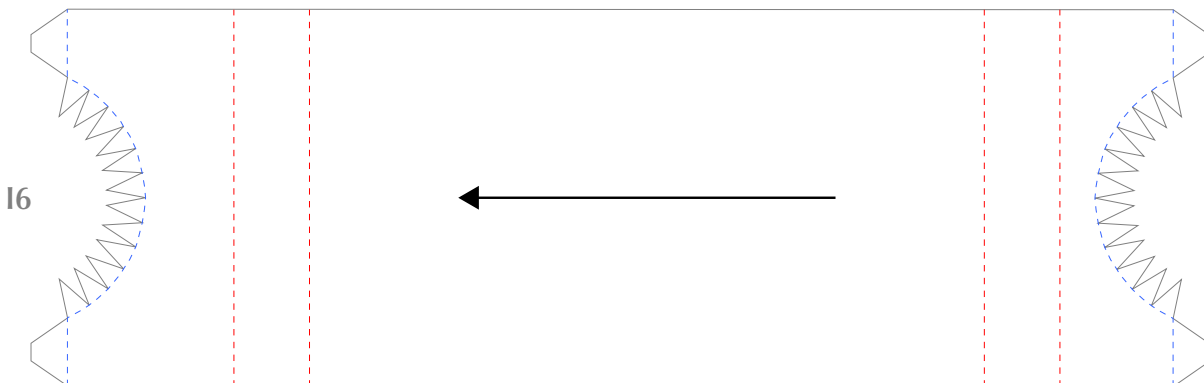



Authentic Repaint

