

Repainted by: Richard Schmittovich

© 2021 Edwin Rodriguez

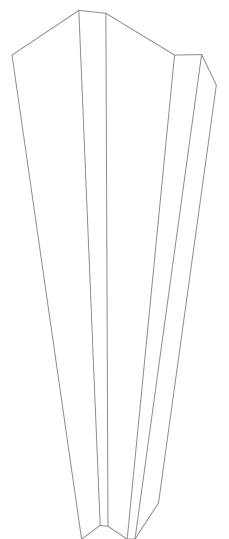

Blank space for 787-10 variant

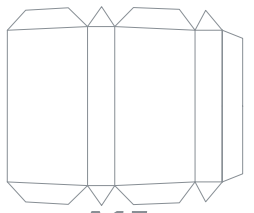
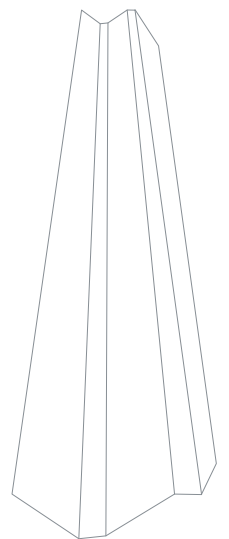
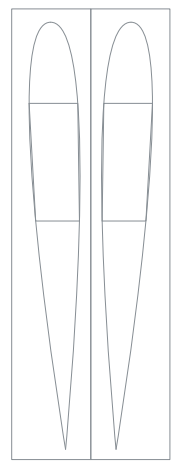
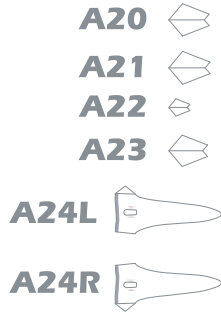
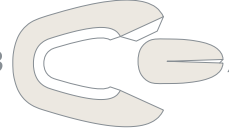
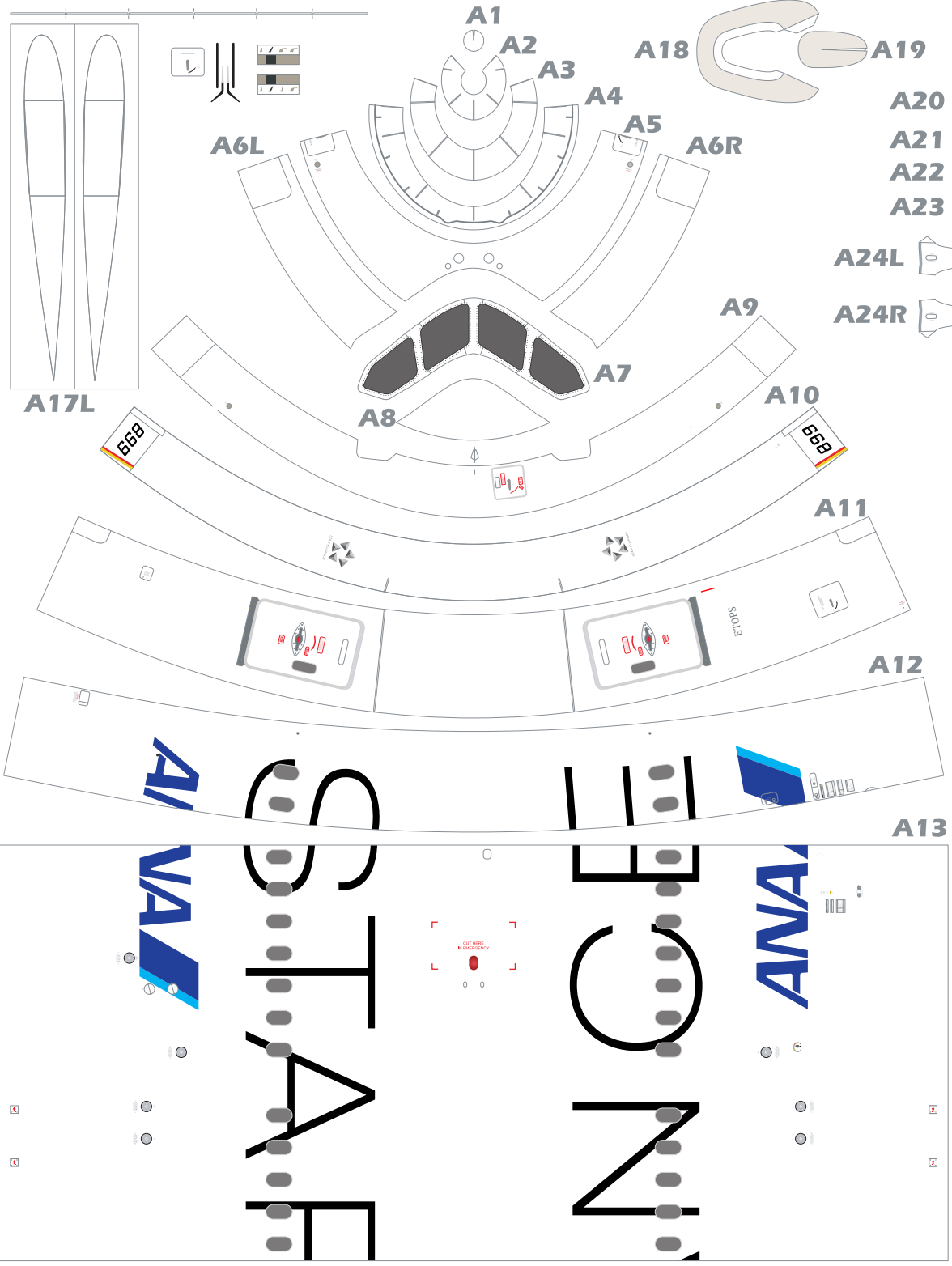
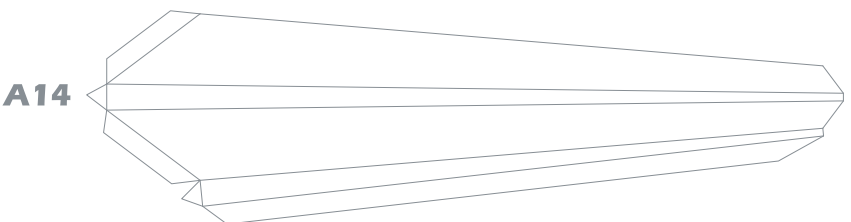

Instructions



Scan

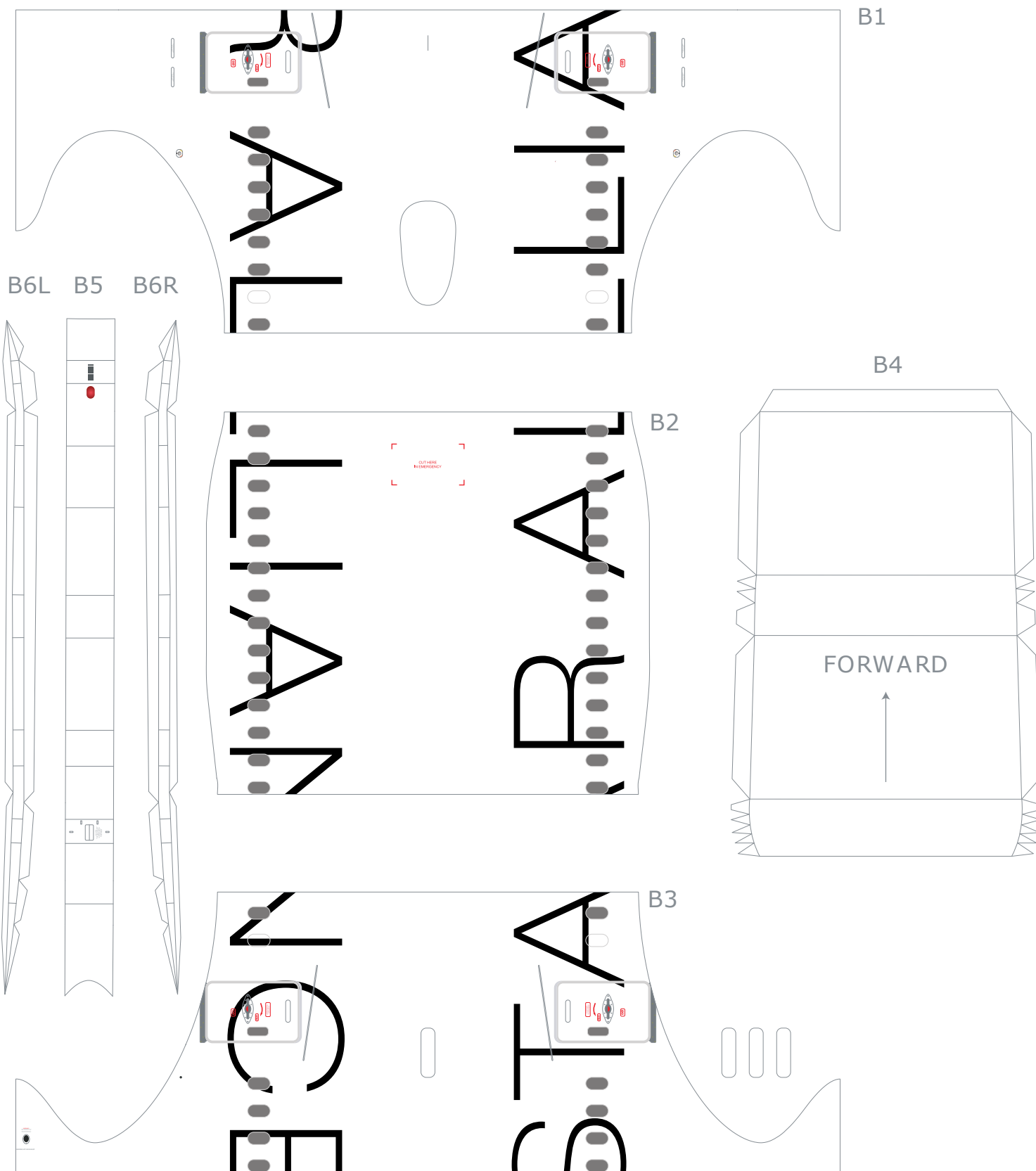

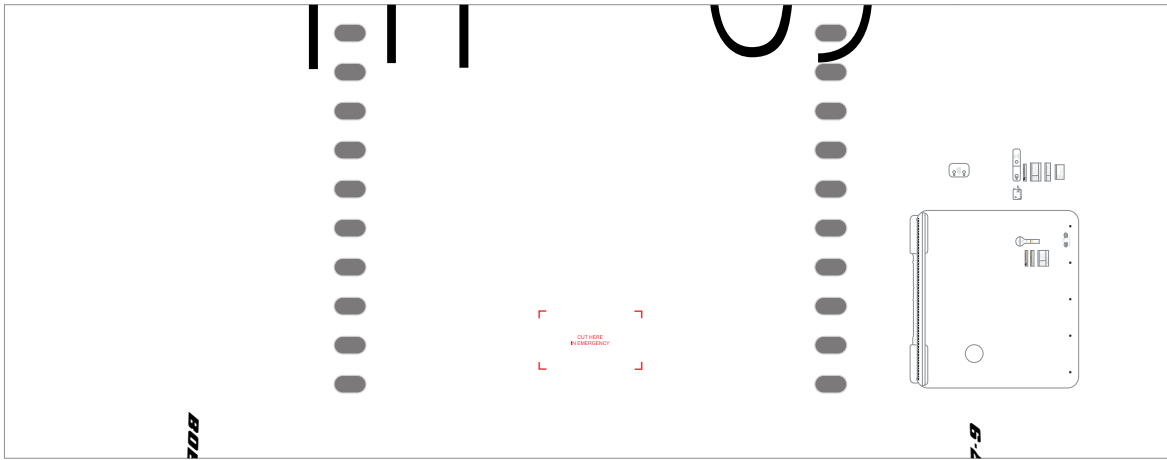

Blank space for 787-10 variant

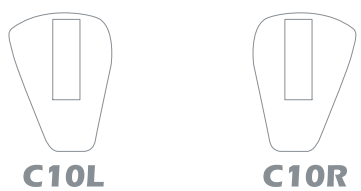
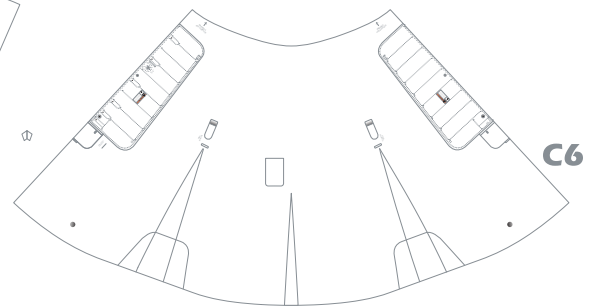
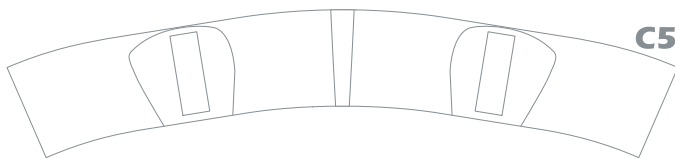
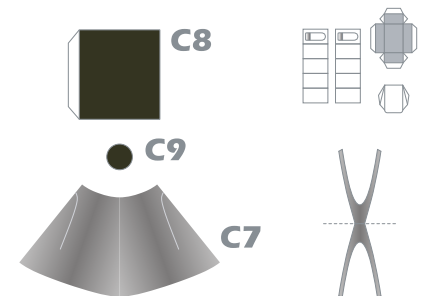
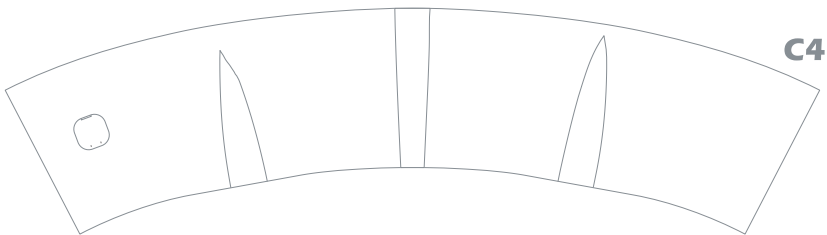
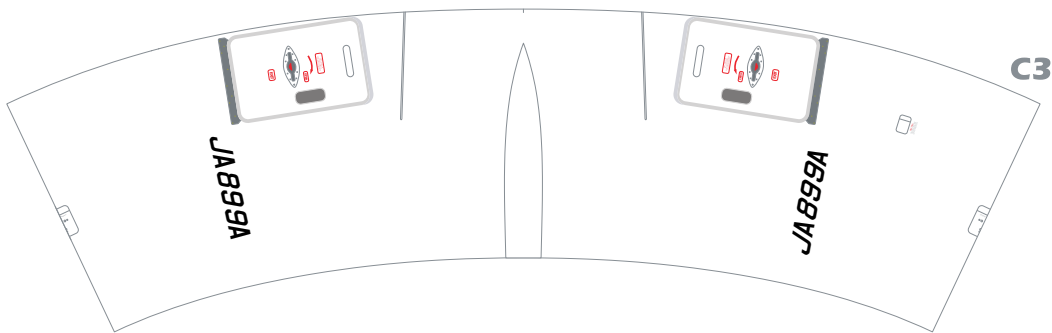
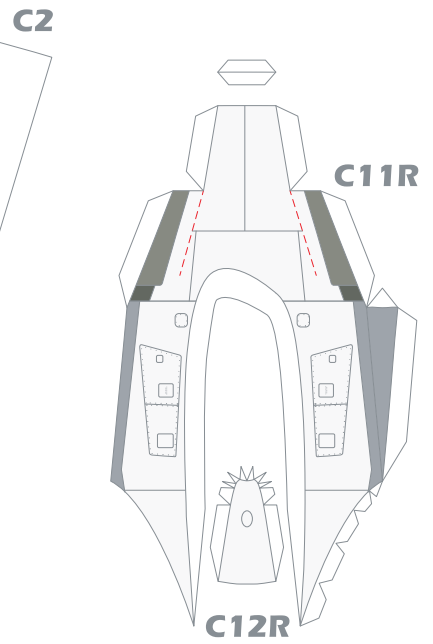
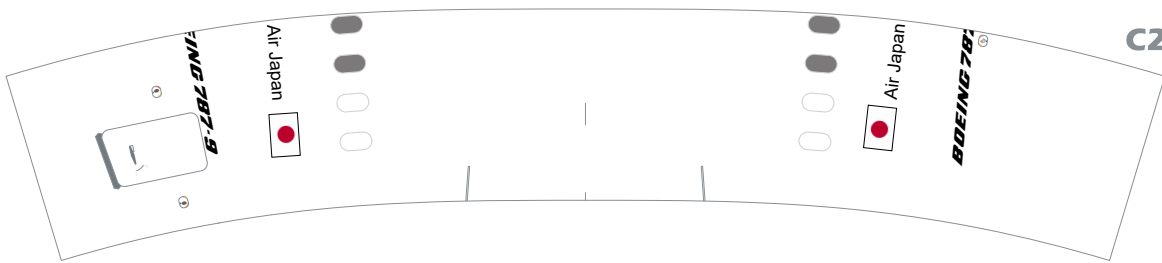
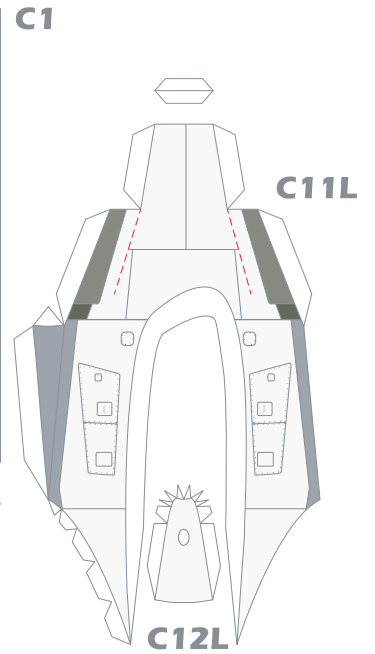

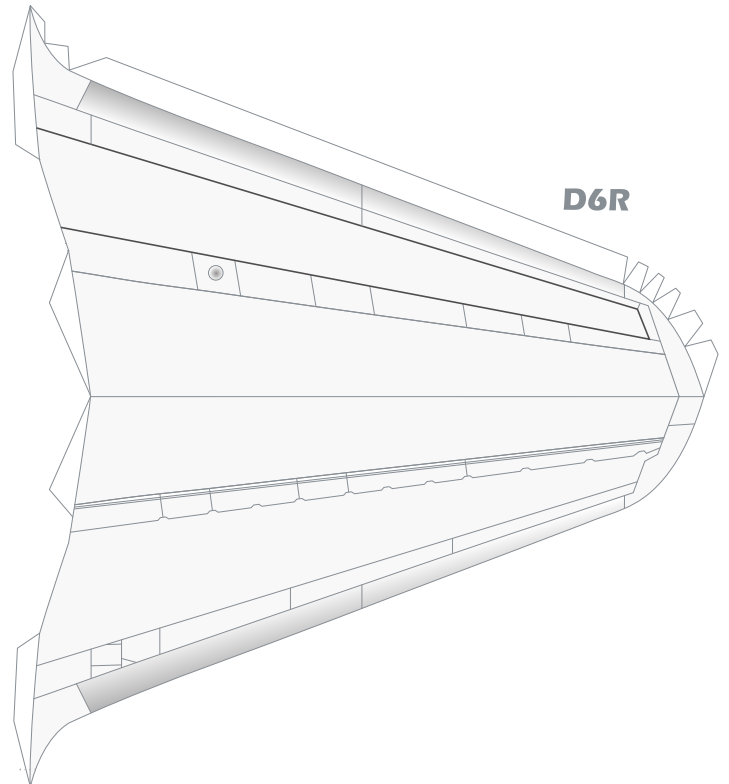
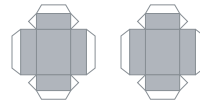
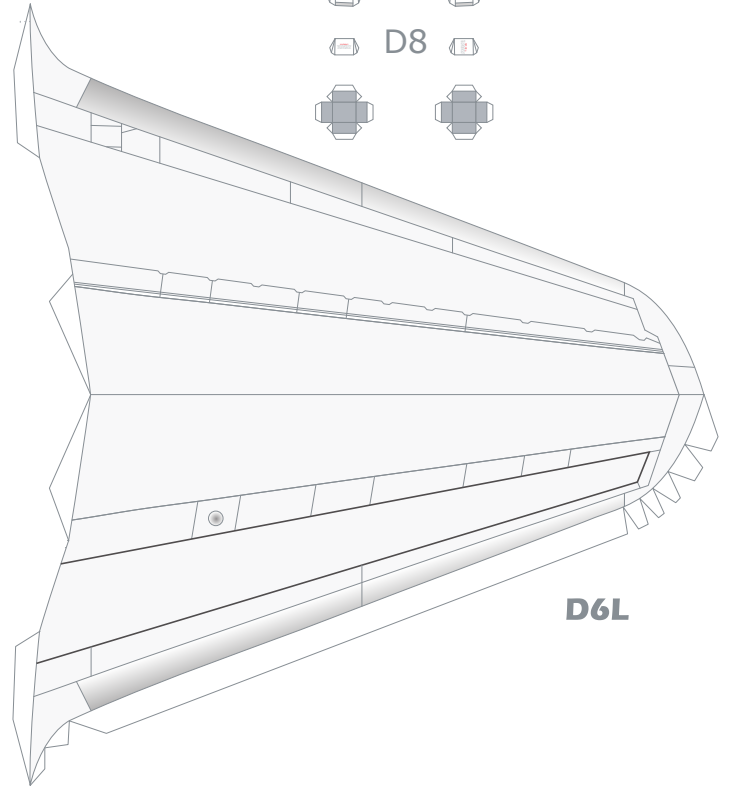
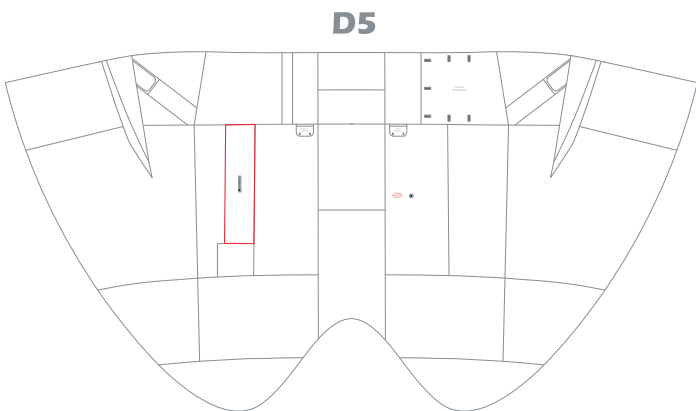
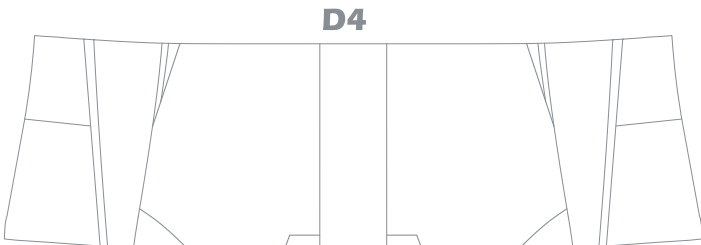
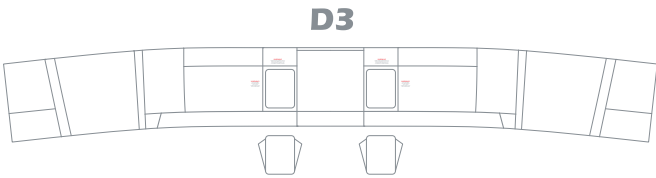
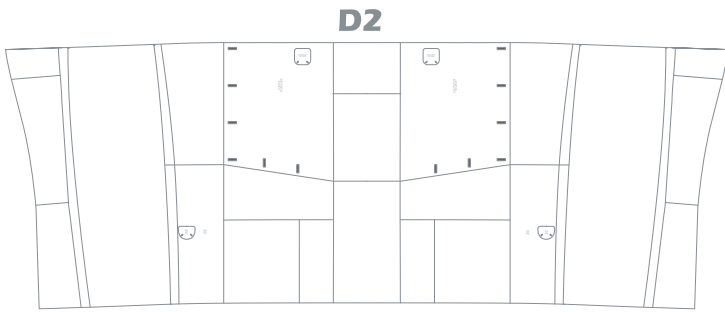
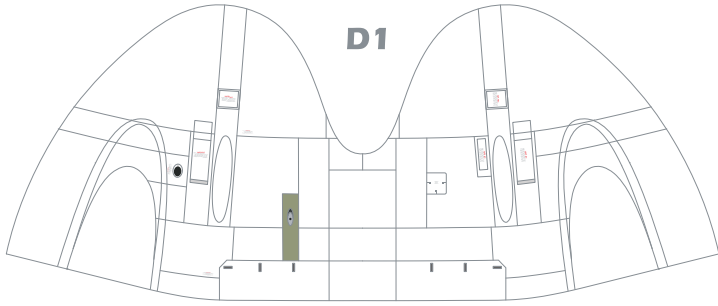

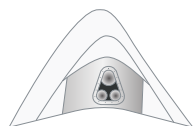

E2L

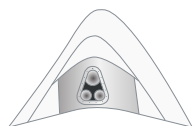

E2R

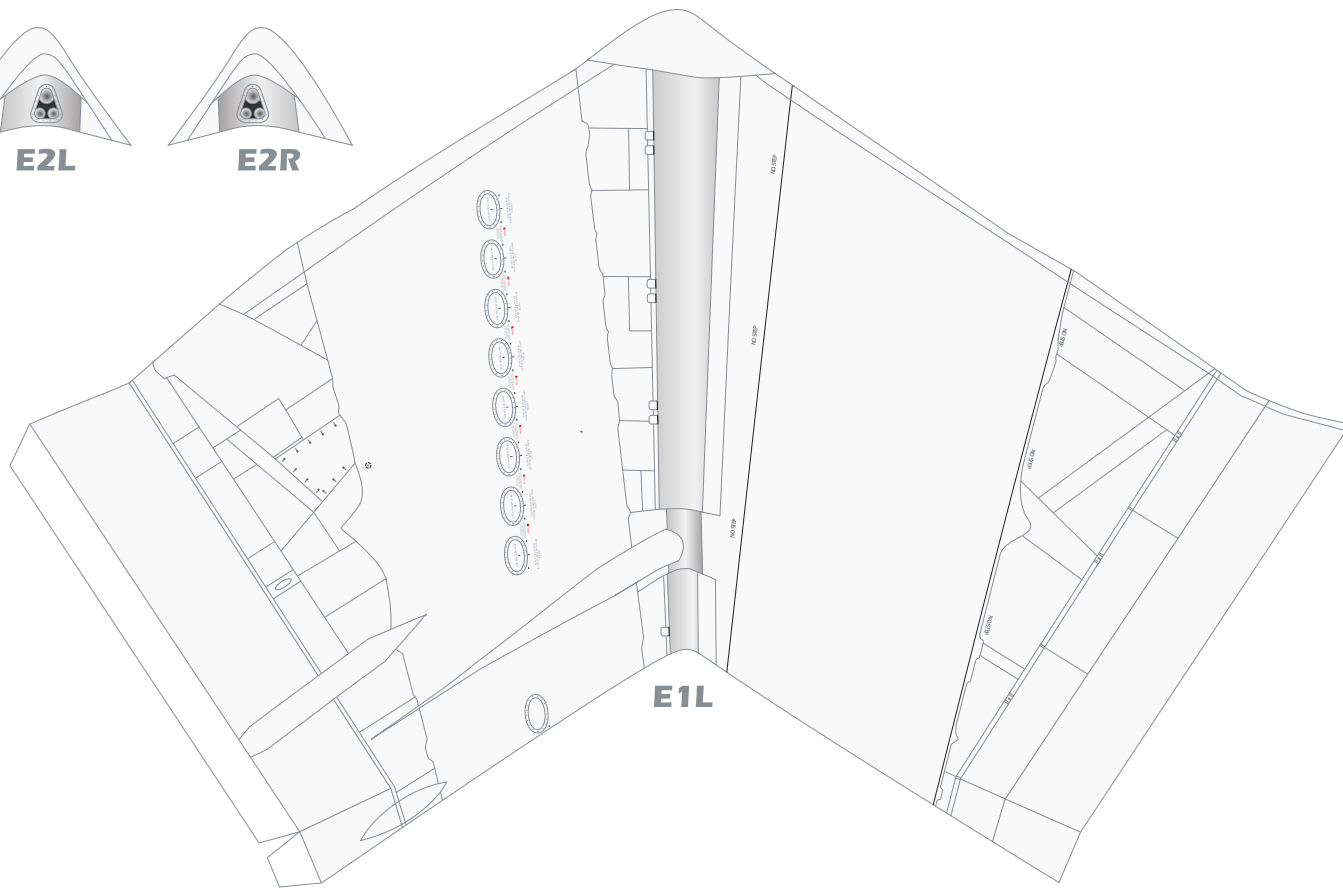

E1L

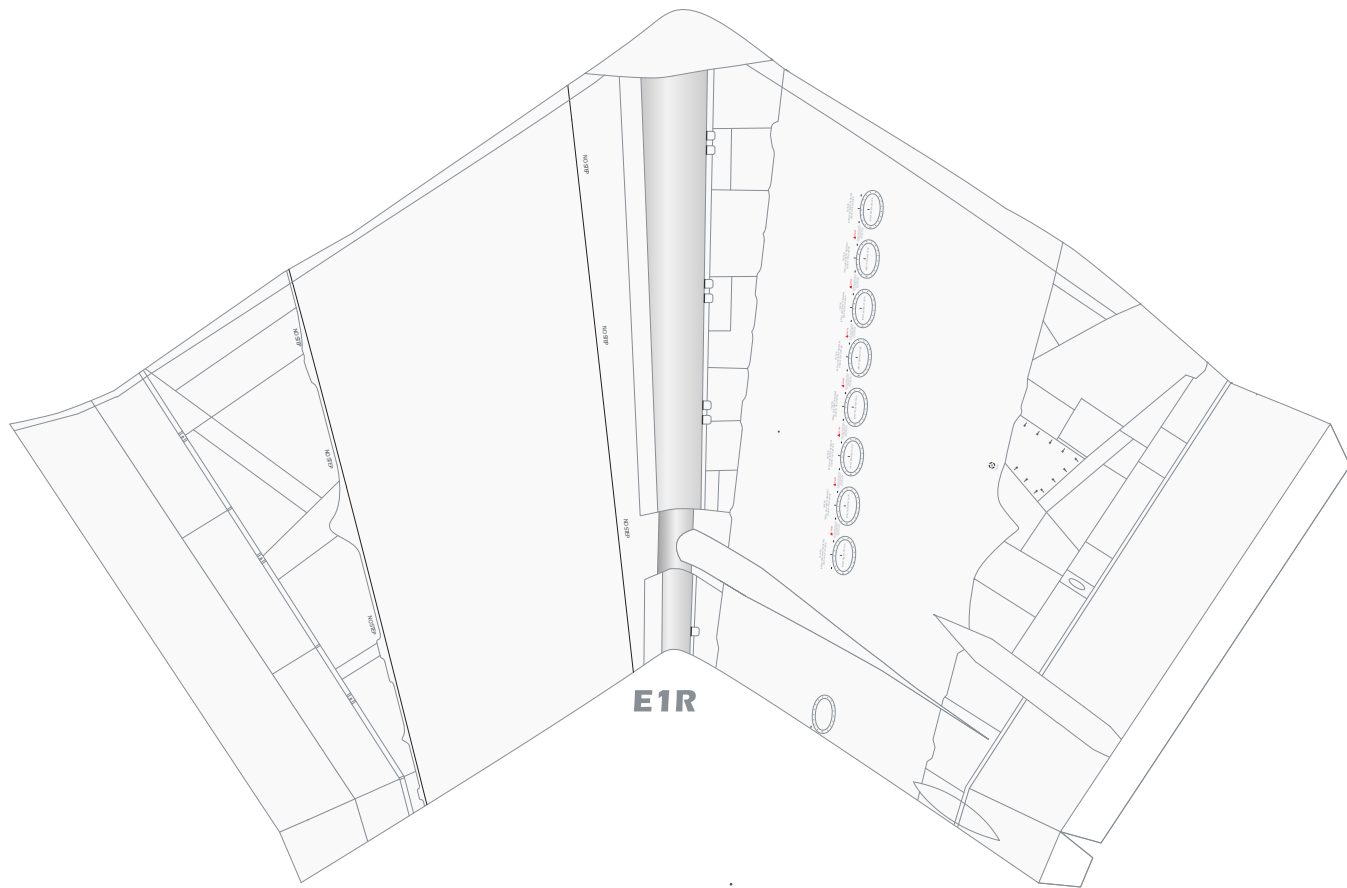

E1R

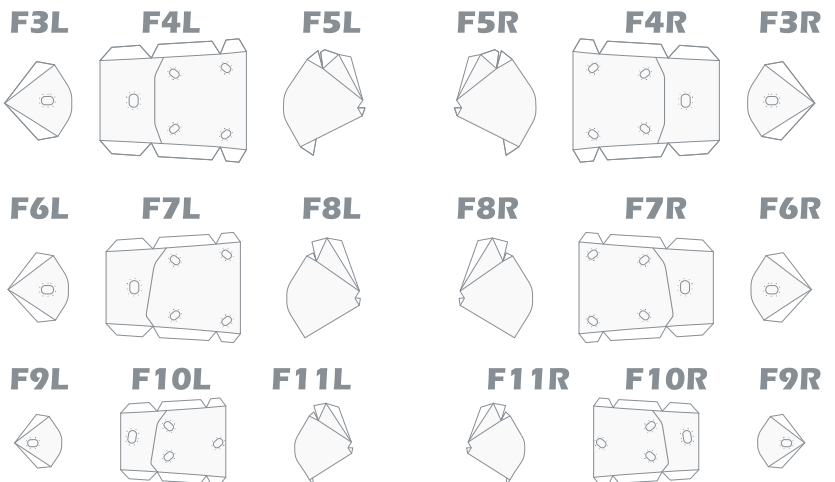
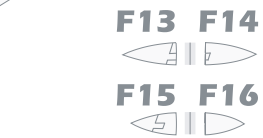
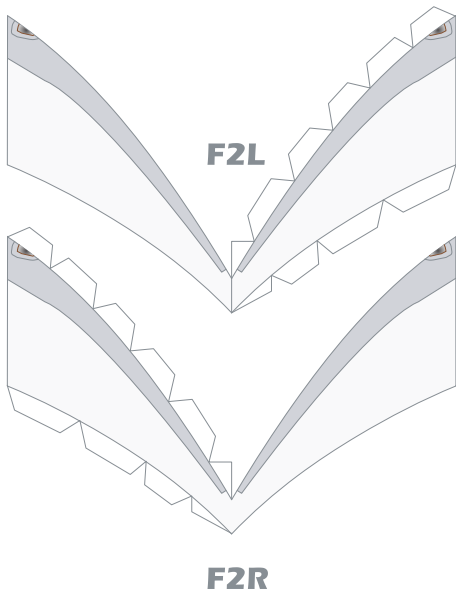
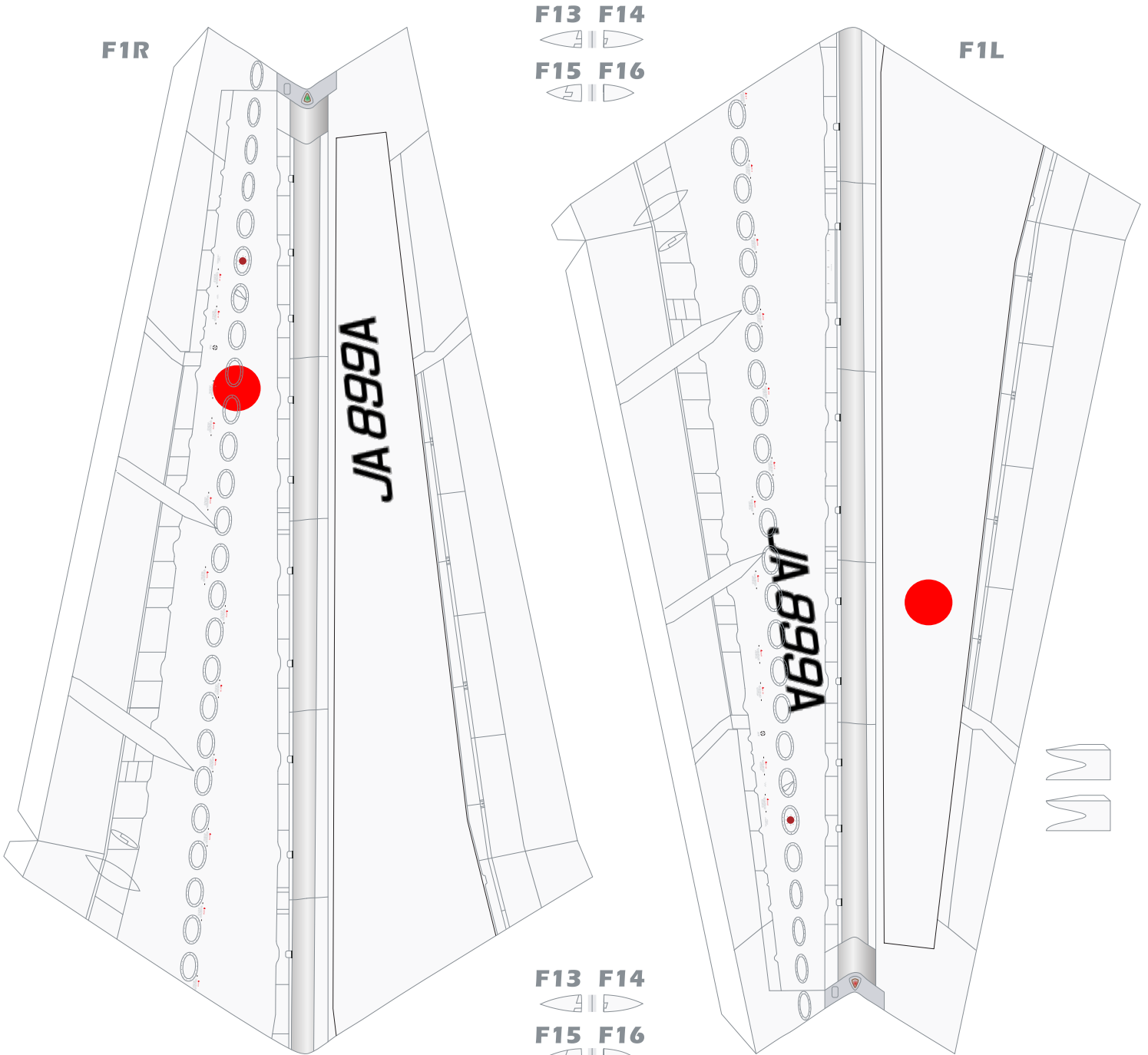

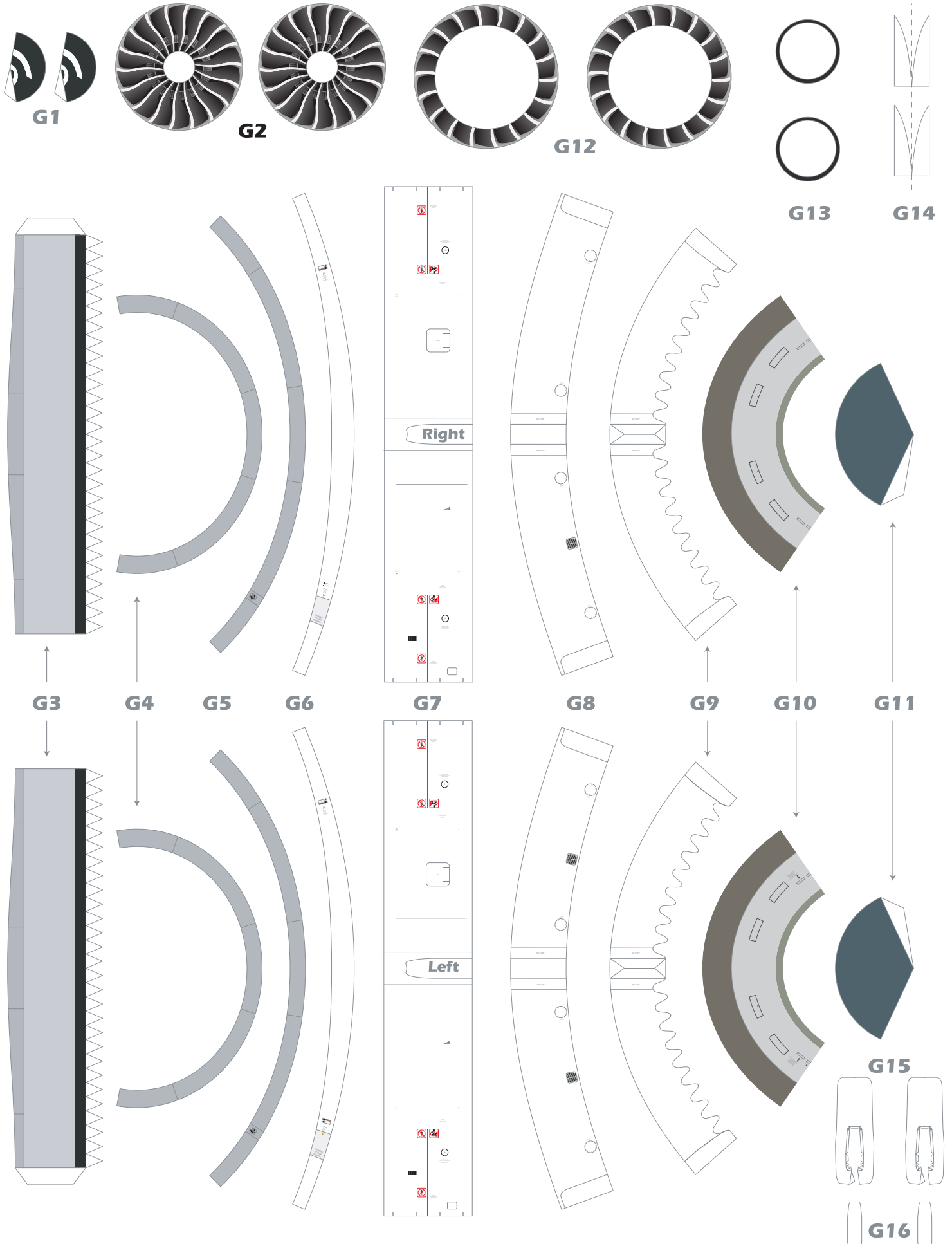

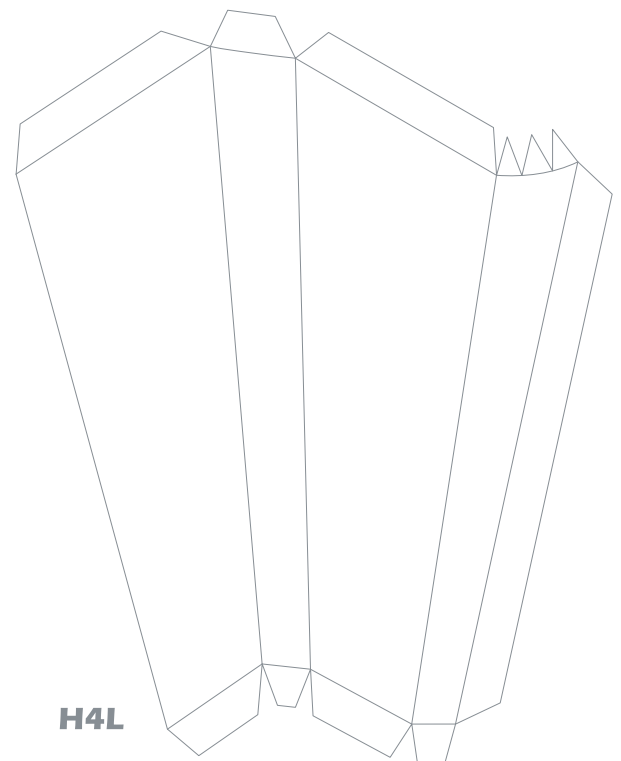
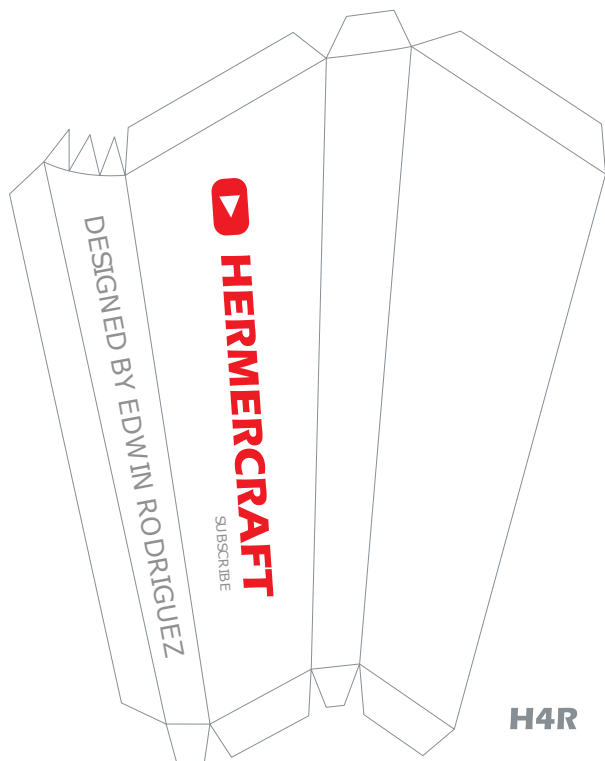
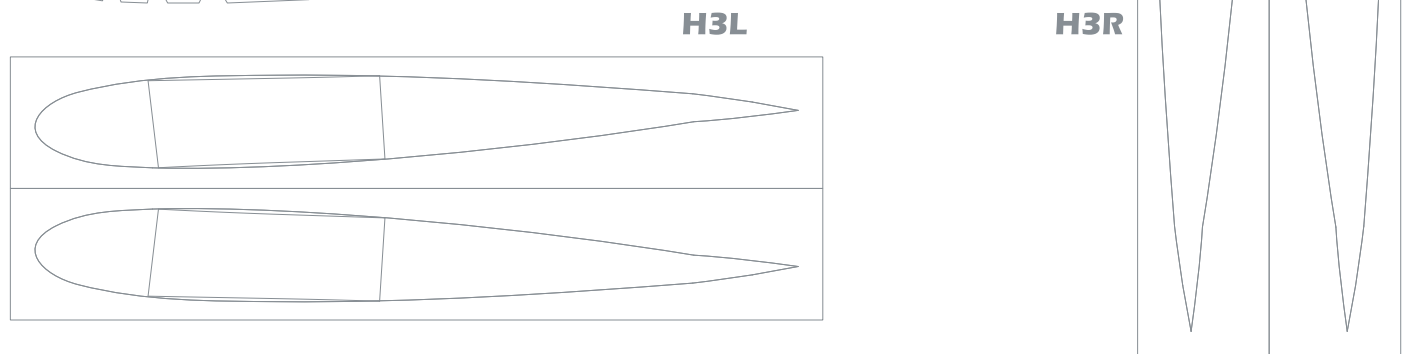
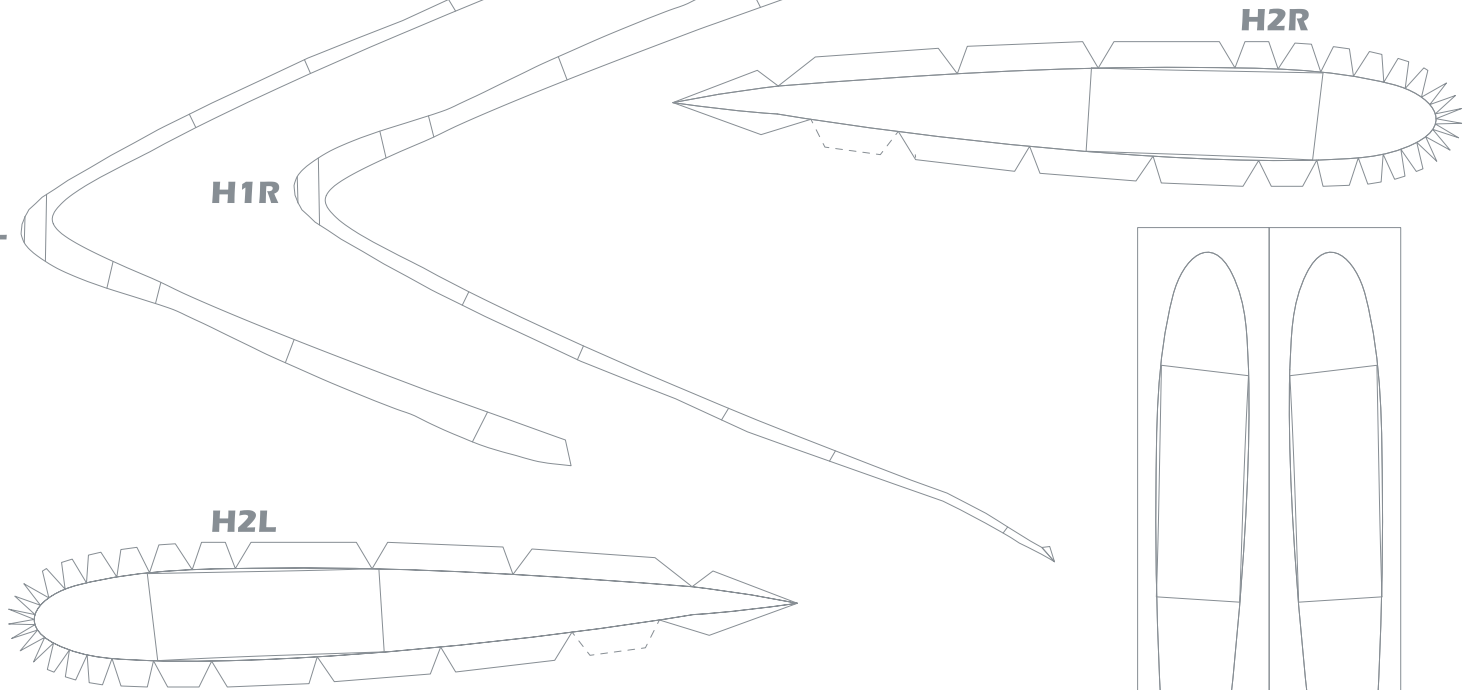
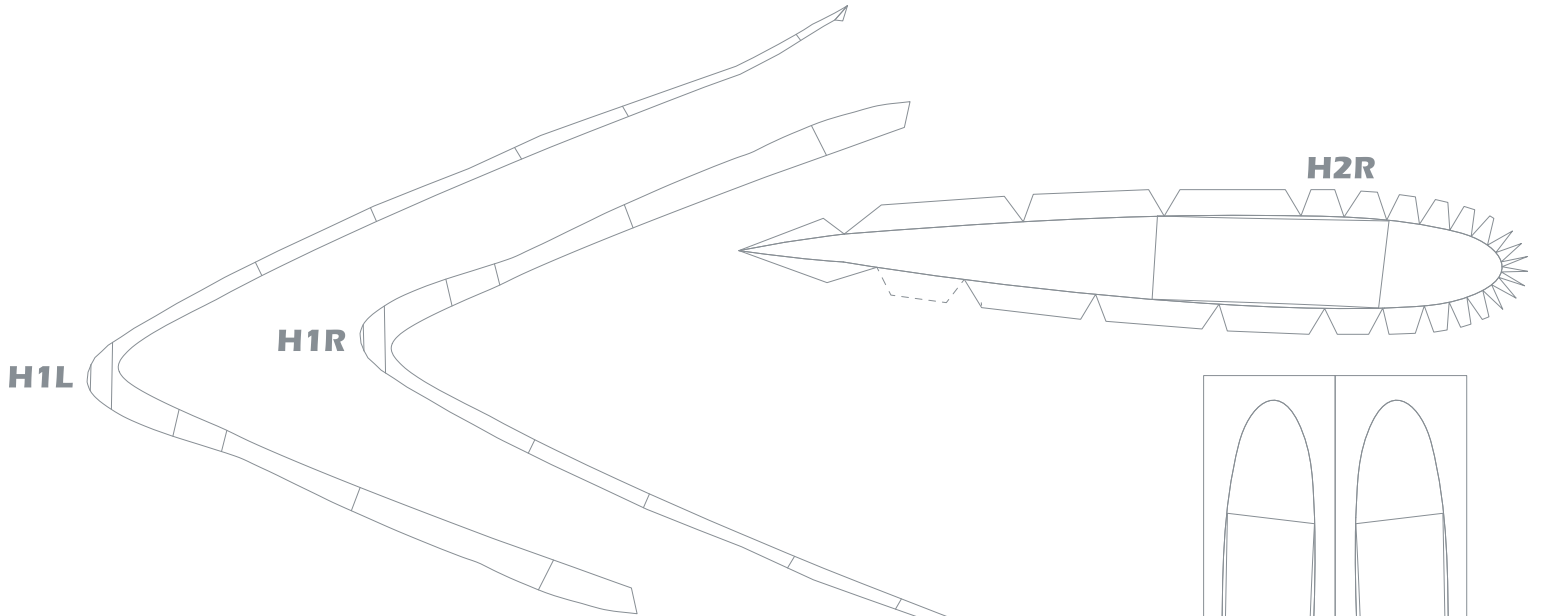

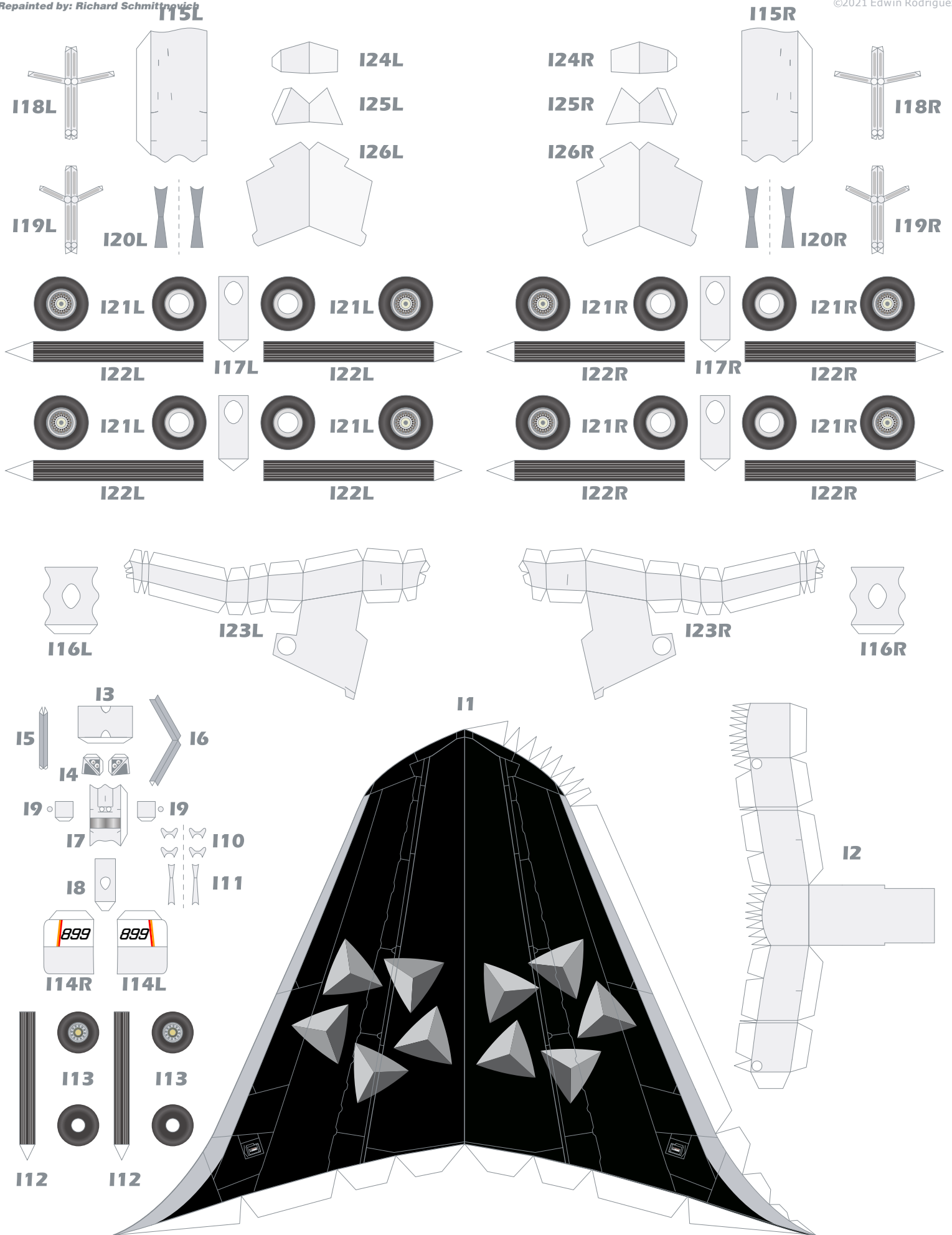

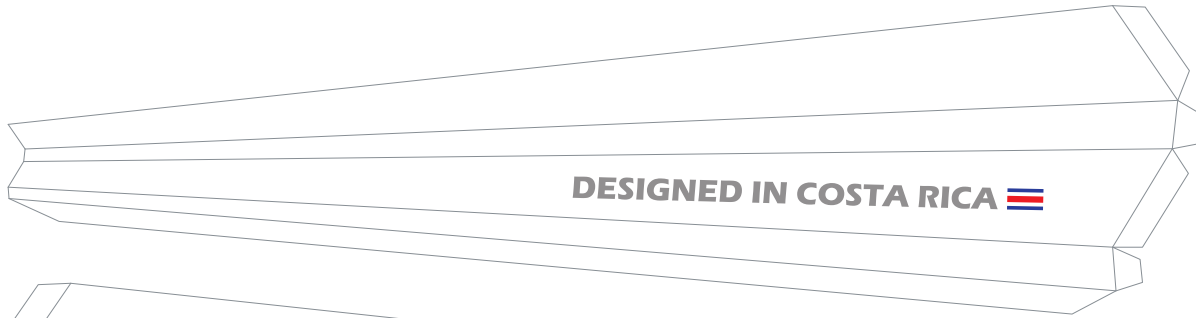

J1L

DESIGNED IN COSTA RICA 



J1R

FREE MODEL, DO NOT SELL THE FILE!!!

