

Authentic Repaint

# CITYCRAFT

## PAPERMODELS



# BUZZ



## ***BOEING 737 MAX 8 -200***

### ***BUZZ Boeing 737 MAX 8 -200***

080

Buzz is a Polish airline headquartered in Warsaw. Formerly called Ryanair Sun, it is a subsidiary of the Irish airline company Ryanair Holdings and a sister airline to Ryanair, Ryanair UK, Malta Air and Lauda Europe.

Formed in 2017 and initially positioned as a charter airline without any scheduled services, Buzz operates scheduled flights on behalf of Ryanair, and charter flights in its own right, out of Poland. In March 2019, Ryanair announced that Ryanair Sun would be rebranded as Buzz in autumn 2019. Buzz commenced operations in January 2020. On April 3, 2018, the carrier received an air operator's certificate granted by the Polish Civil Aviation Authority. It started operations on 23 April 2018 and the first flight took place on 26 April 2018, on the route from Poznań–Ławica Airport to Zakynthos International Airport.

The Boeing 737 MAX is the fourth generation of the Boeing 737, a narrow-body airliner manufactured by Boeing Commercial Airplanes (BCA), a division of American company Boeing. It succeeds the Boeing 737 Next Generation (NG) and competes with the Airbus A320neo family. The 737 MAX is based on earlier 737 designs, with more efficient CFM International LEAP-1B engines, aerodynamic changes, including its distinctive split-tip winglets, and airframe modifications. The new series was announced on August 30, 2011. It took its maiden flight on January 29, 2016 and was certified by the U.S. Federal Aviation Administration (FAA) in March 2017. The first delivery was a MAX 8 in May 2017 to Malindo Air, with whom it commenced service on May 22, 2017.

Scale: 1:100  
Length: (395mm)  
Width: (358mm)  
Parts: 300 (12 pages)

Attach the parts in order.  
A1 - I6  
You can choose to make either a grooved style (With Wheels)  
or an in-flight style (without wheels) aircraft.



- \*This model is designed for papercraft and is different in several ways from the real plane
- \*Build the model by carefully reading the Assembly Instructions.
- \*The final size of the model may vary slightly depending on the configuration of your printer





Authentic Repaint

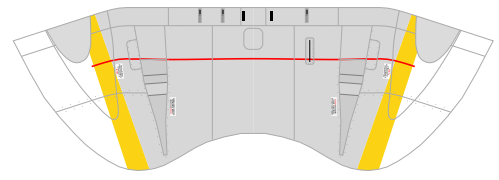
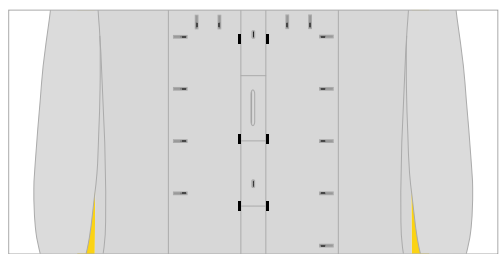
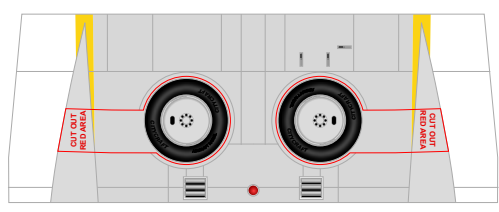
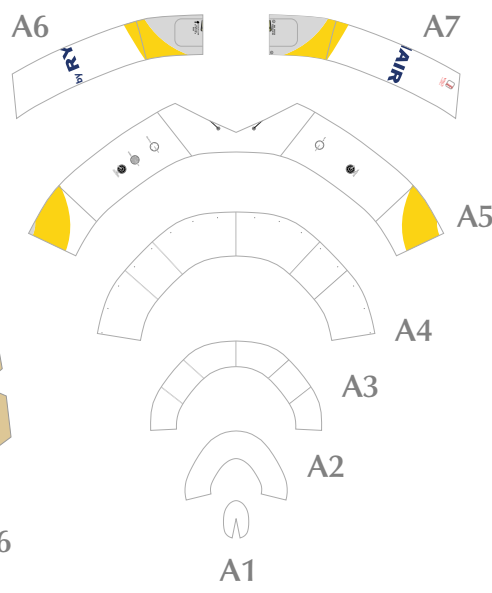
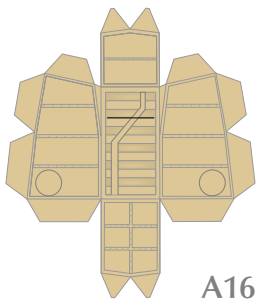
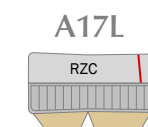
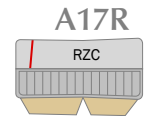
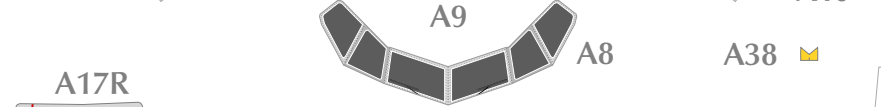
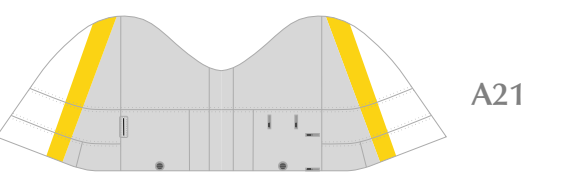
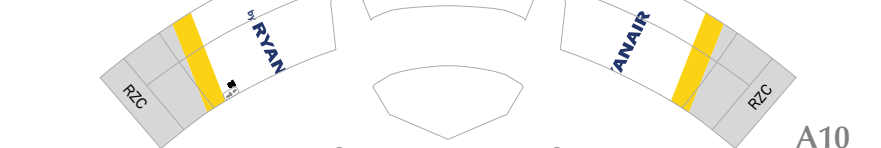
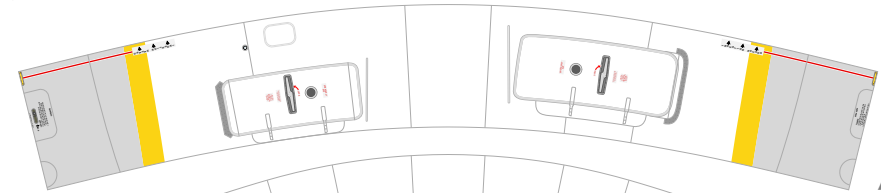
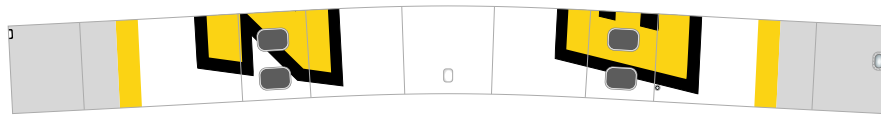
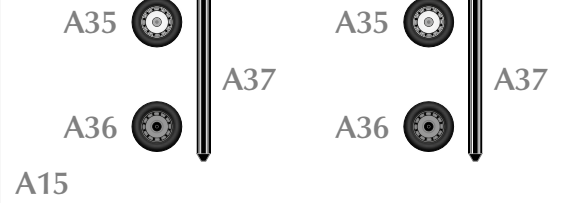
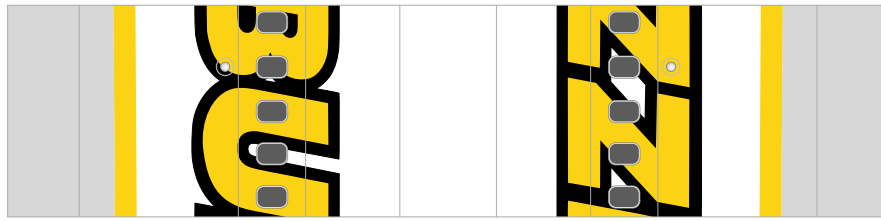



Authentic Repaint

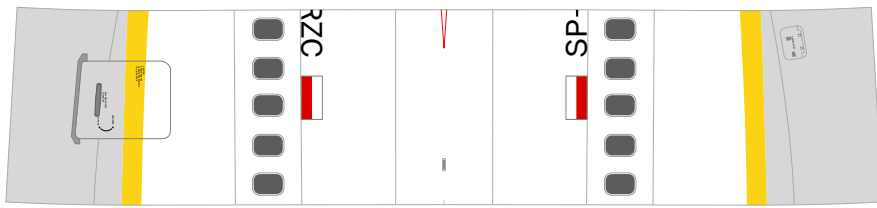

B6

B7L



B8L



B8L



B8L



B7R



B8R



B8R



B8R



B9

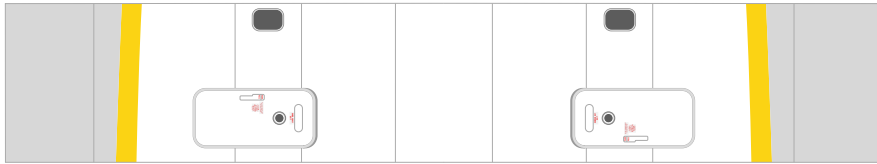
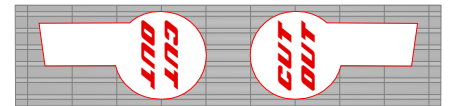

B5

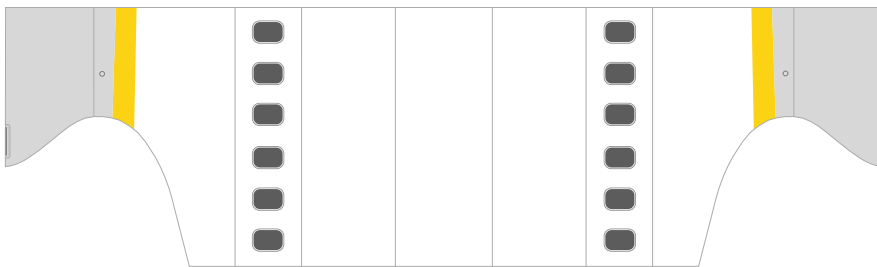

B4

B10

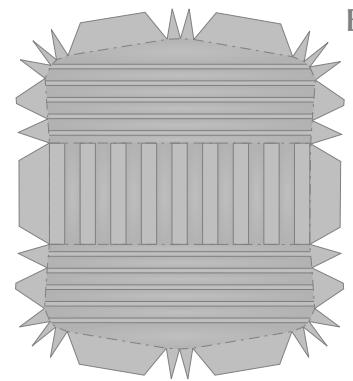

B11L



B12L



B11R



B12R

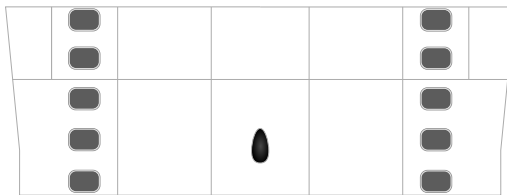

B3

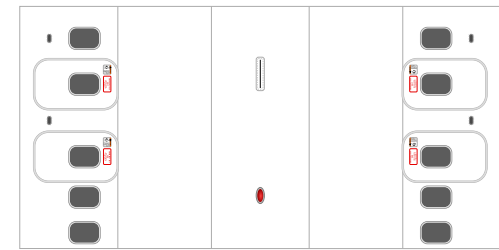

B2

B13L



B14L

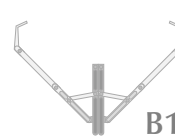

B15L



B16L



B17L\*



B18L\*



B19L\*



B20L\*



B21L\*



B13R



B14R

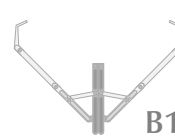

B15R



B16R



B17R\*



B18R\*



B19R\*



B20R\*



B21R\*

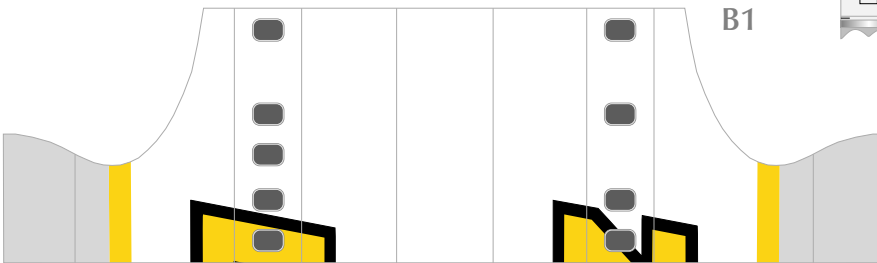

B1

B22L

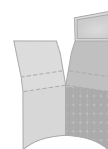

B22R

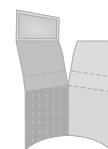

B23L



B23R





Authentic Repaint

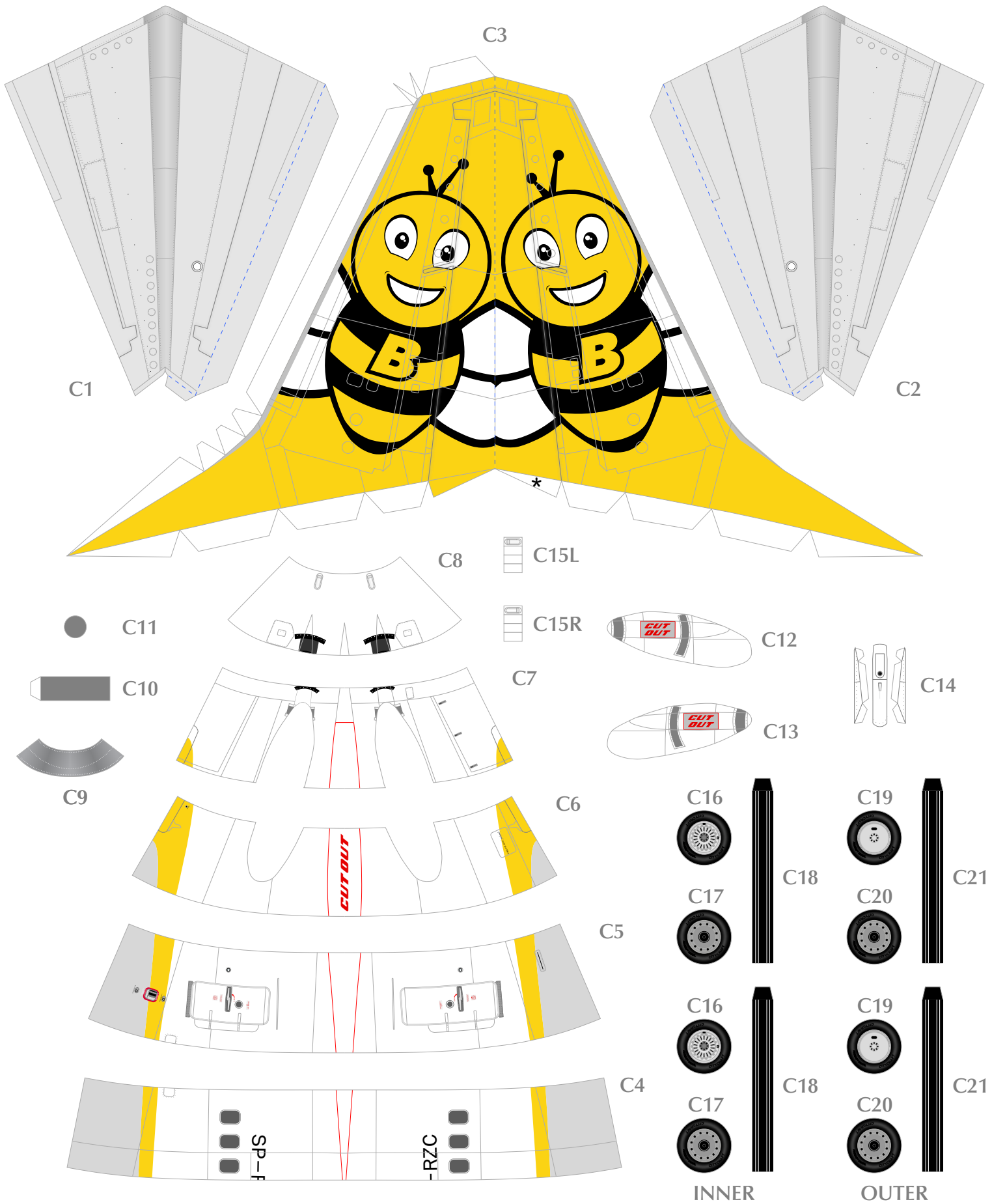



Authentic Repaint

Engines: CFMI Leap 1B

By Mario Solorzano

D1L



D2L

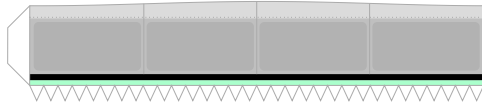

D1R



D2R

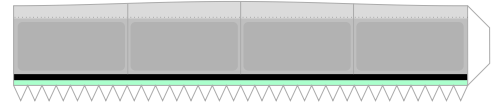

D3L



D24L



D24R



D3R



D4R

D4L

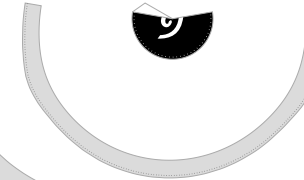
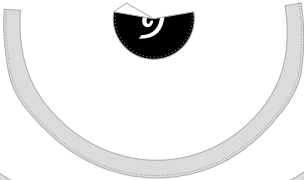

D5L



D25L



D5R

D6L

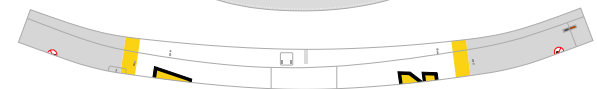

D25R

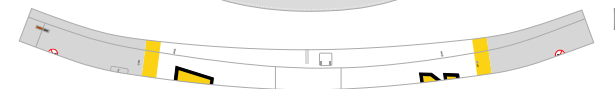

D6R

D7L

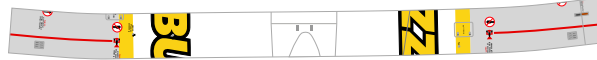

D26L

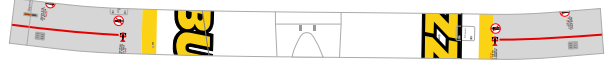

D7R

D8L

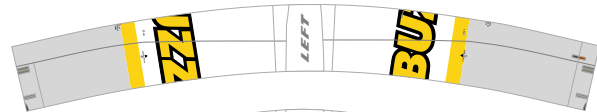

D26R

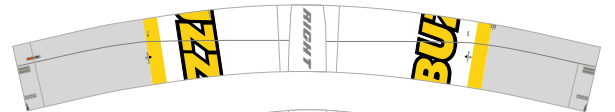

D8R

D9L

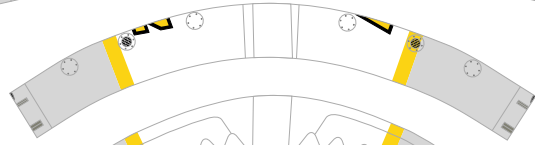

D27L

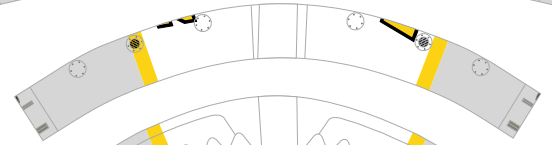

D9R

D10L

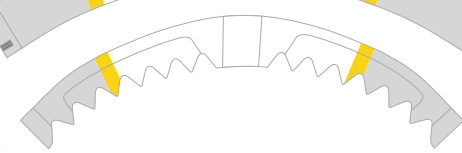

D27R

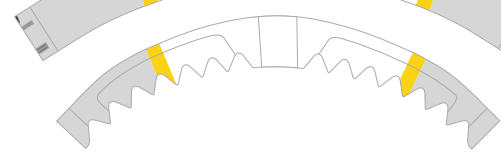

D10R

D11L



D18L

D11R



D18R

D12L

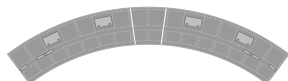

D12R

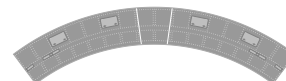

D13L



D13R



D14L

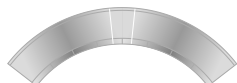

D14R

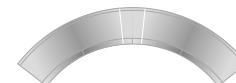

D15L



D15R



D16L



D16R



D17L



D17R



D21L



D22L



D23L

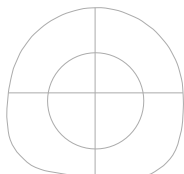

D19L

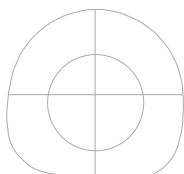

D20L

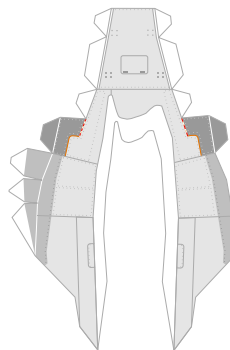

D24L

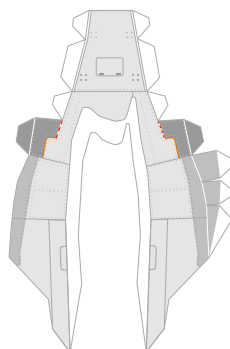

D24R



D21R



D22R



D23R

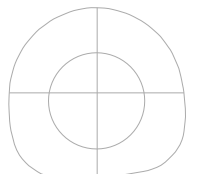

D19R

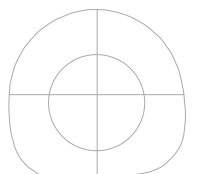

D20R



Authentic Repaint

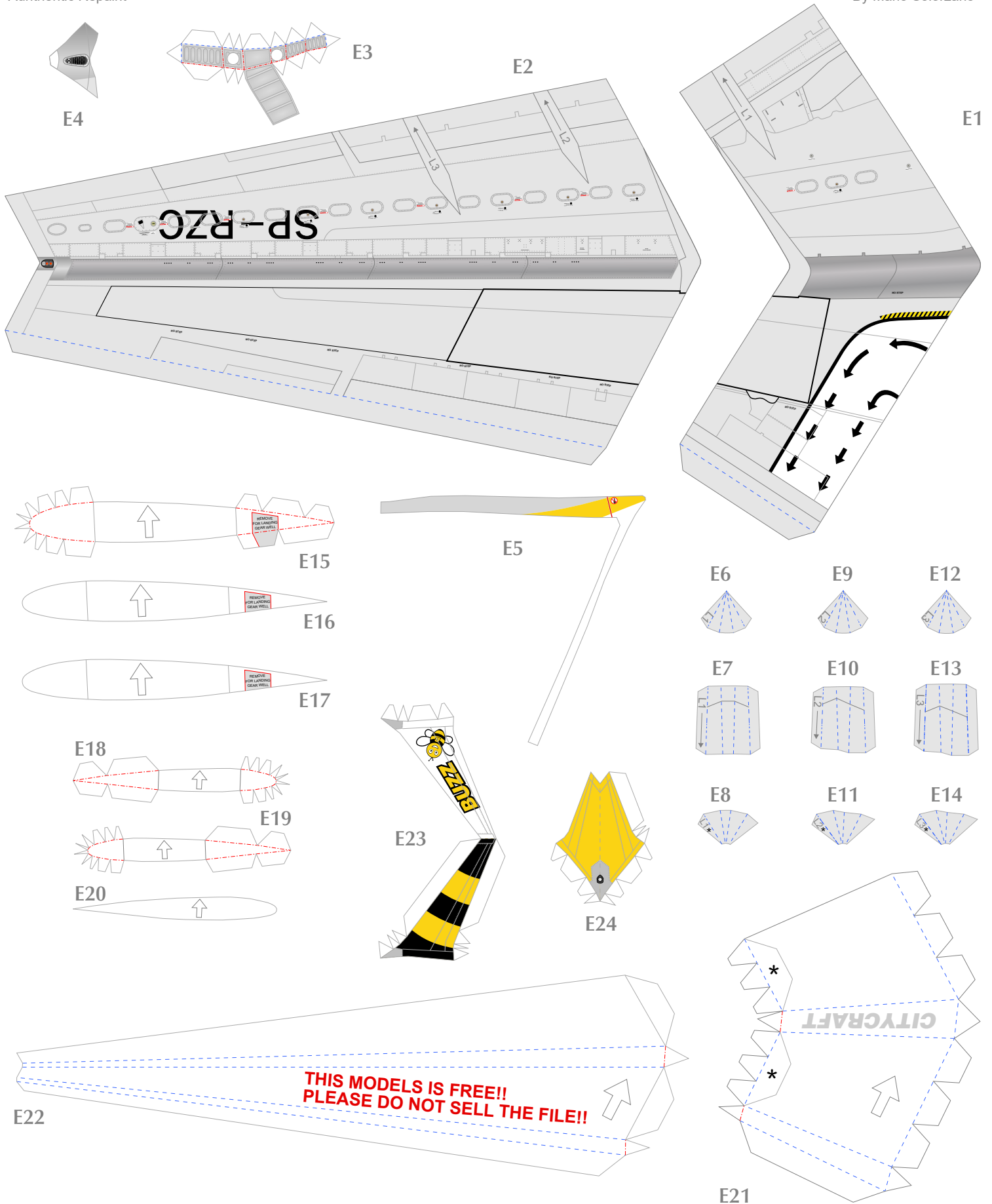





Authentic Repaint

By Mario Solorzano

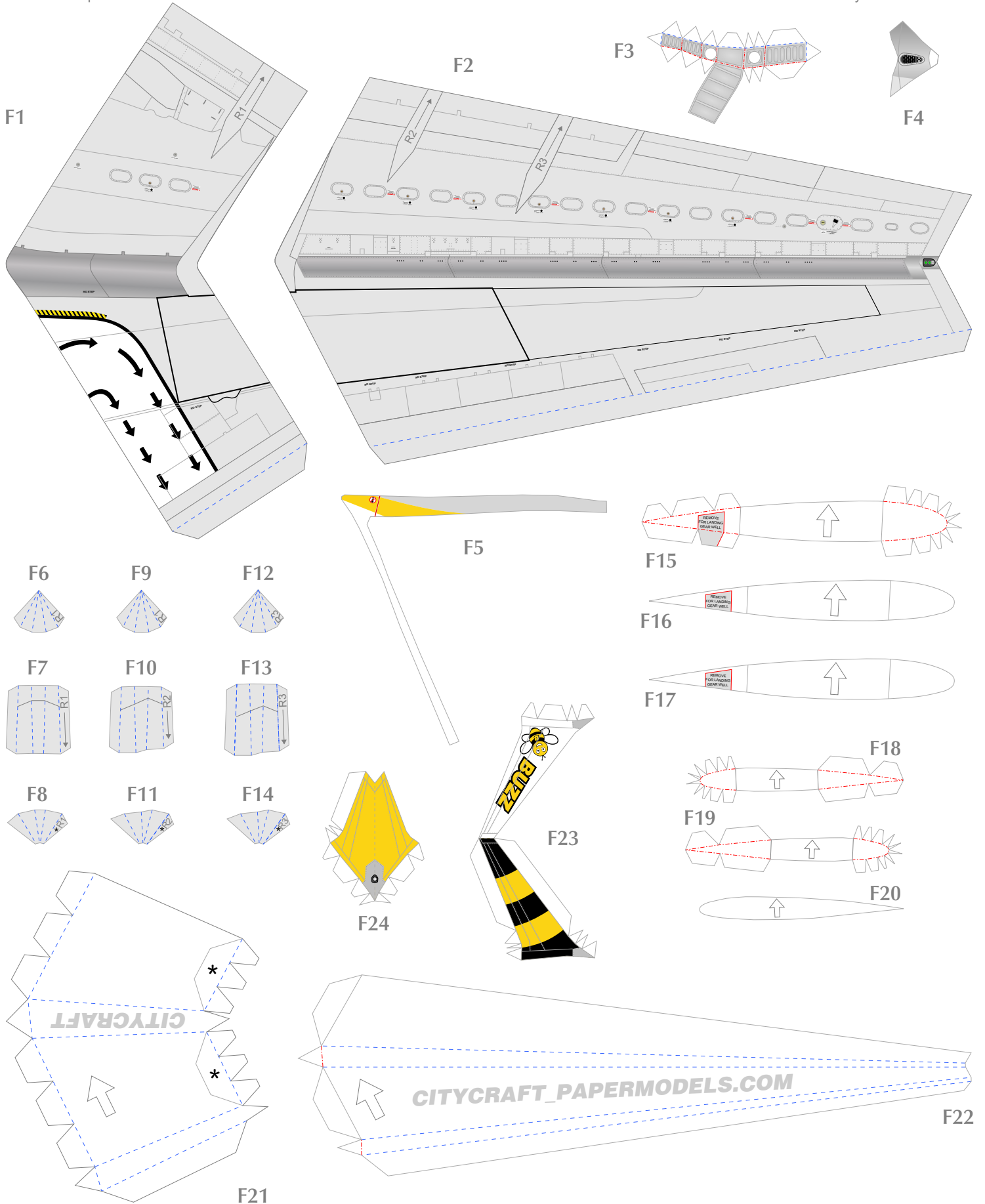

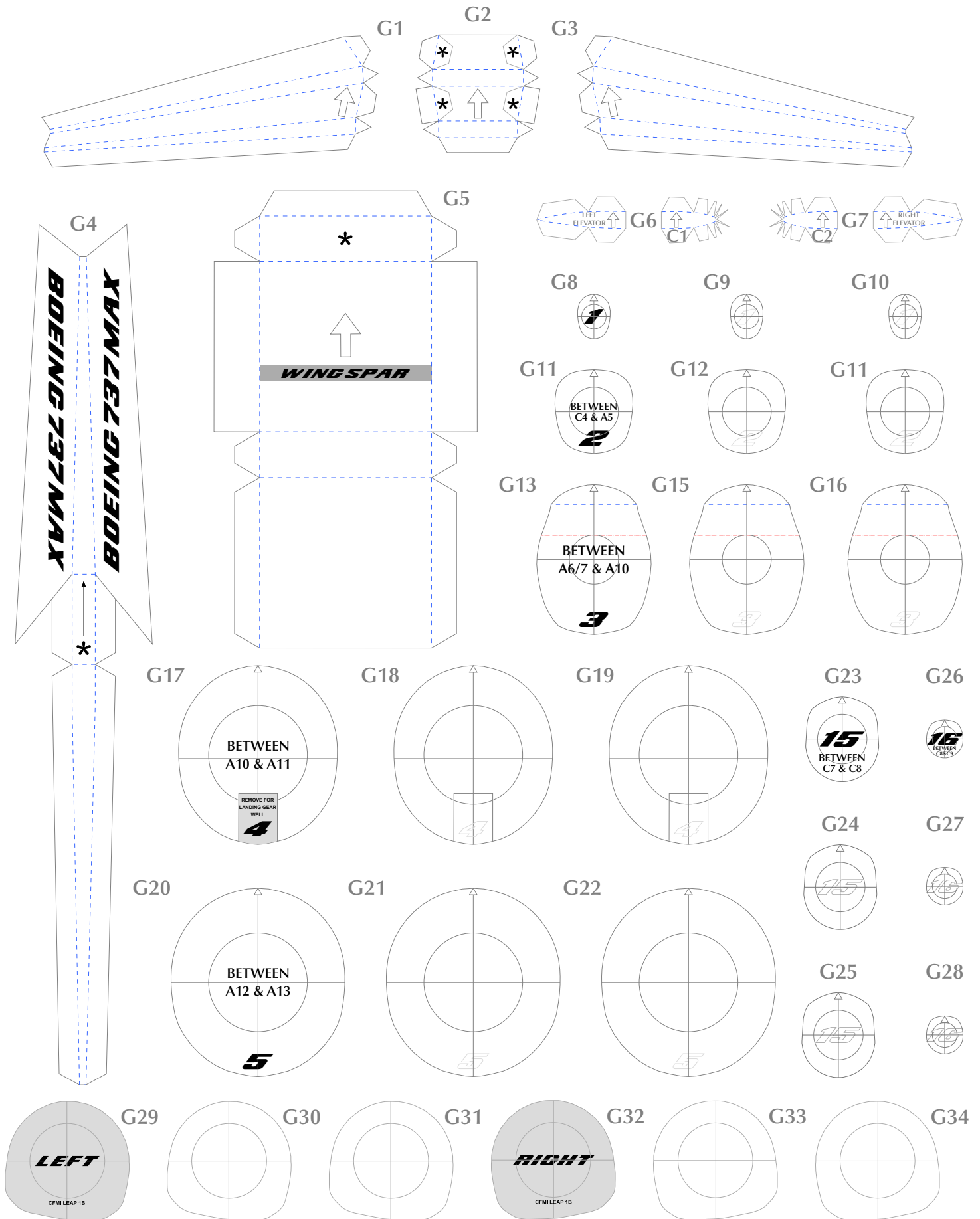





Authentic Repaint

By Mario Solorzano

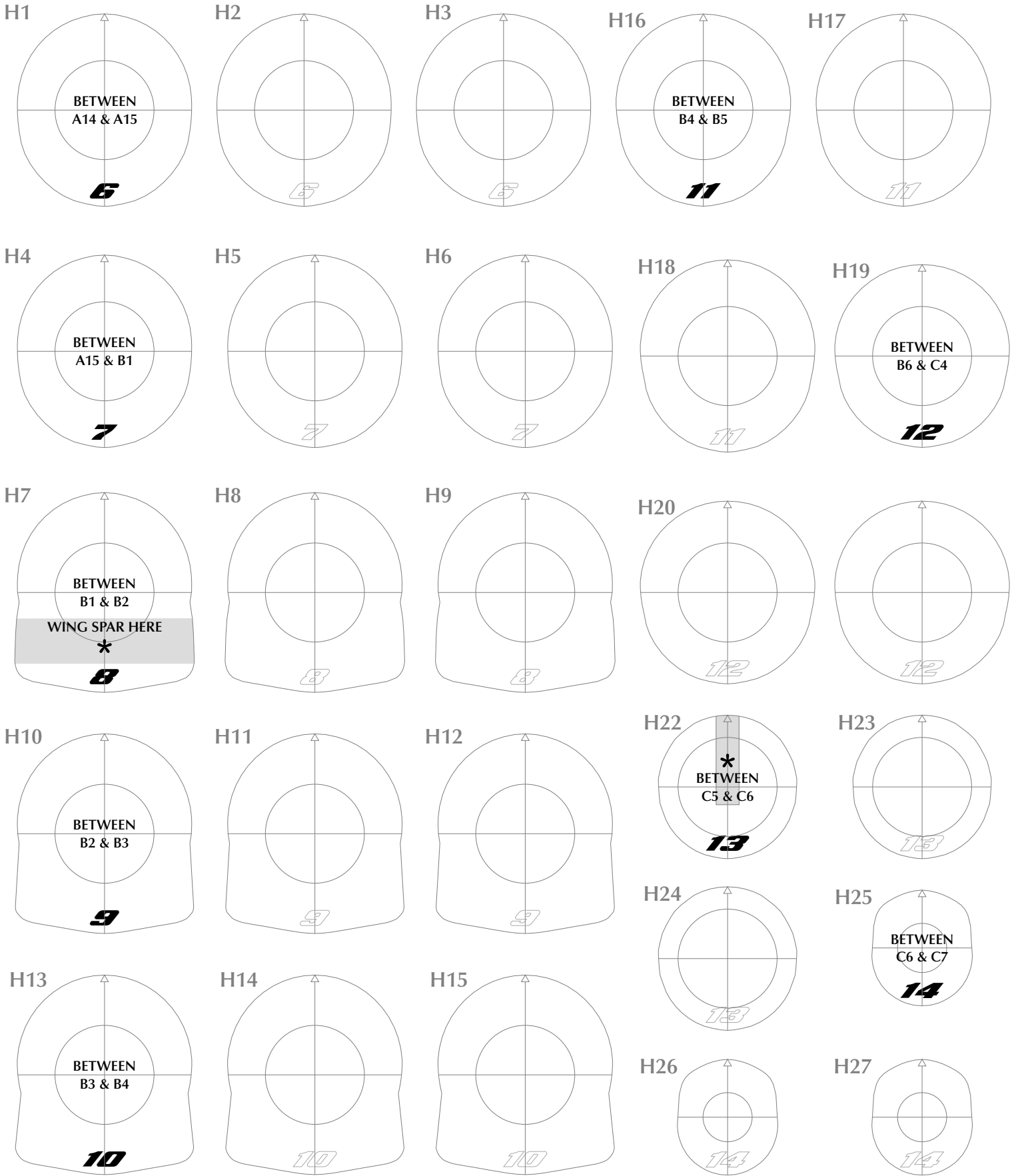



Authentic Repaint

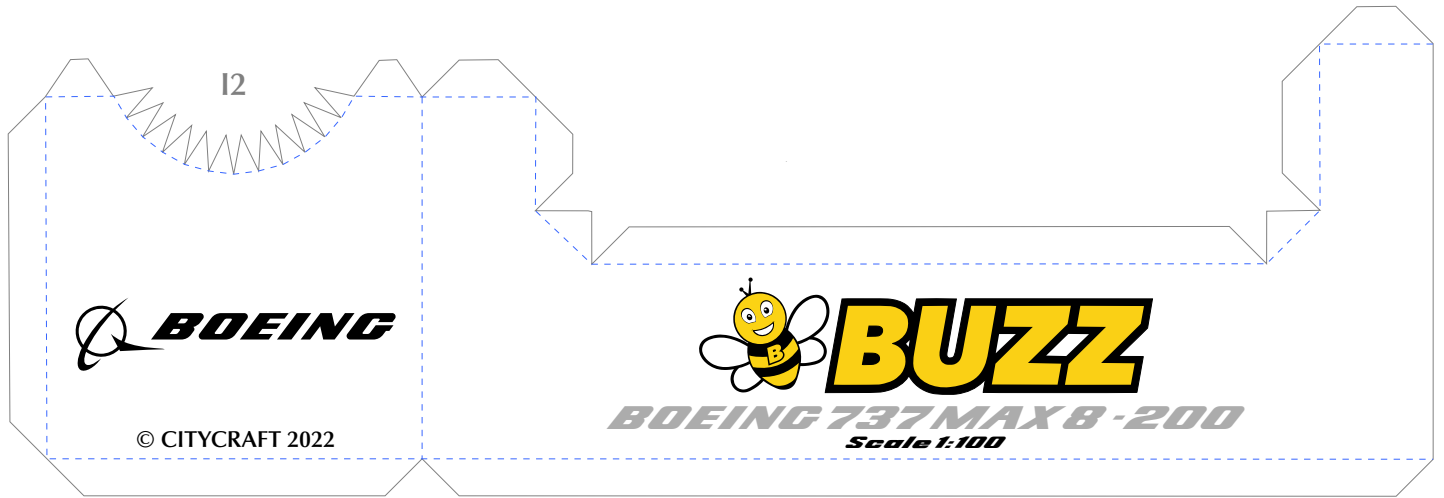
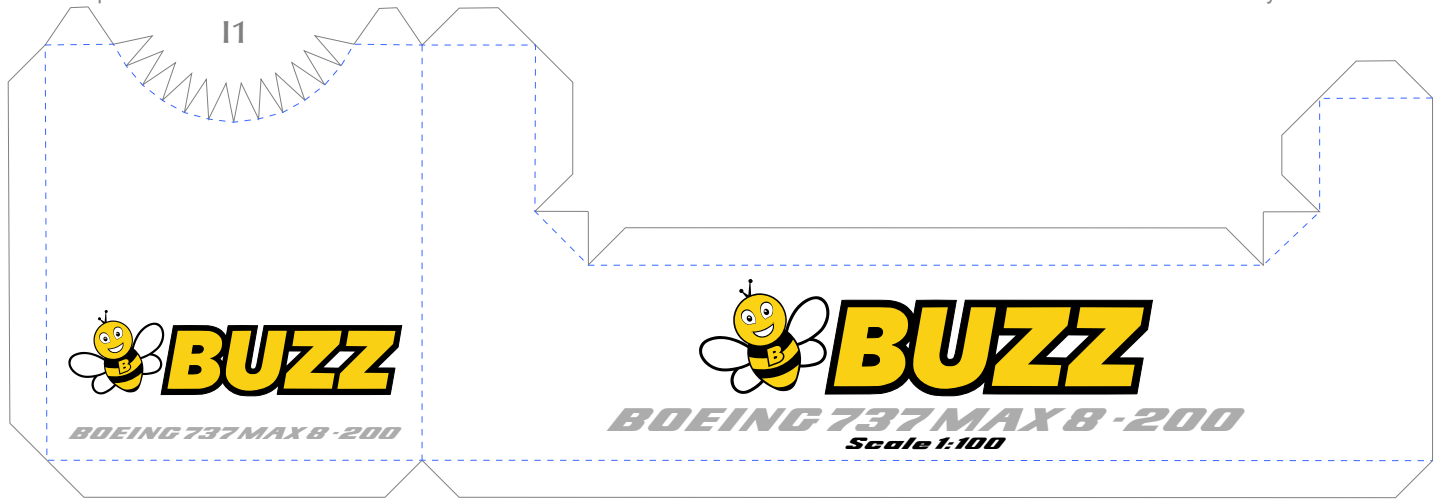

I3

I5

I4



CITYCRAFT  
PAPERMODELS



**WARNING:**  
CHOKING HAZARD - Small parts  
not for children under 5 years



**WARNING:**  
Be careful of SHARP EDGES  
Not for childrens under 5 years.

© 2022 CityCraft All Rights Reserved  
Model designed by (Mario Solorzano)  
<https://citycraftpapermodels.wixsite.com/citycraft>

**THIS MODELS IS FREE!!  
PLEASE DO NOT SELL THE FILE!!**

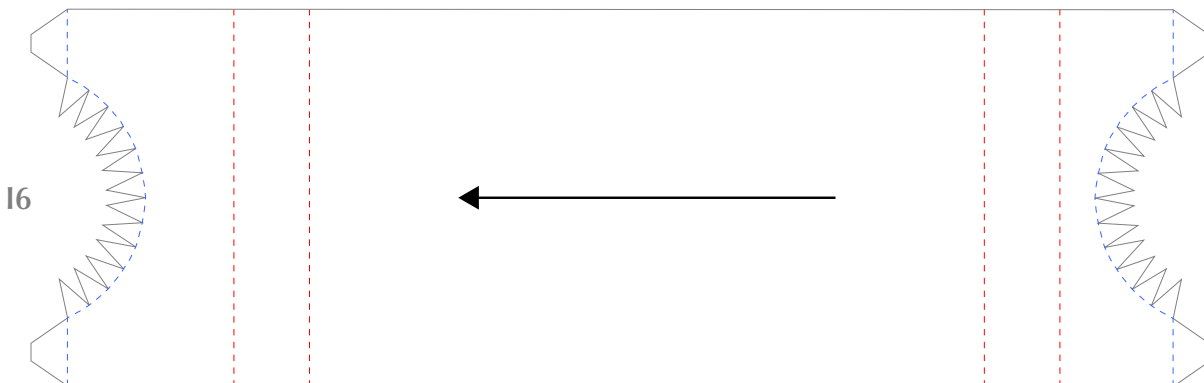

I6



Authentic Repaint

By Mario Solorzano

